

Why is it necessary to tighten fasteners accurately?

Introduction to torque: Torque is the combination of a tangential force acting at a distance from the axis of rotation. When you turn the steering wheel of a car, or push and pull the handlebar of a bicycle, you are generating a torque. Torque is measured in many different contexts from controlling the tightness of a soft drink bottle cap, to measuring the output of a ship's engine. Most applications of torque however are related to the control of threaded fasteners. Threaded fasteners have been in existence for thousands of years. The thread turns rotation into linear movement. The primary purpose of this linear movement is to clamp together two or more pieces of material. This is called a joint. The fastener must create a clamp force so strong that the pieces of material do not move apart during use of the assembled product. The clamping force should have been calculated by the designer who will have studied the forces acting on the joint.

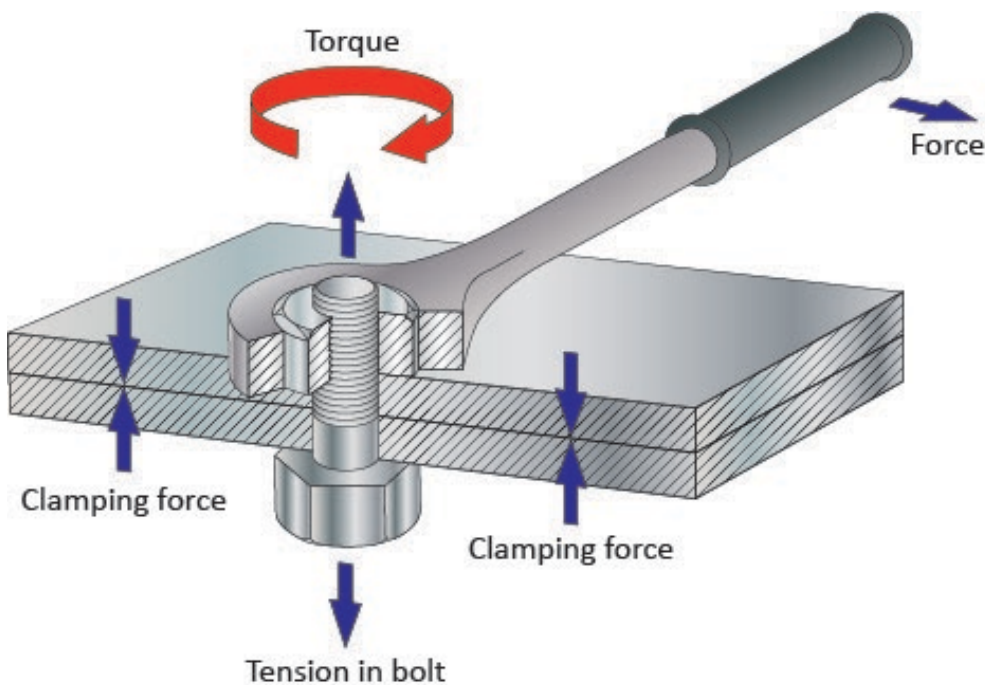

The next challenge for the designer is to translate the force into a torque. This is because it is easier to measure torque than force. When calculating the required torque, the designer will make some assumptions about the materials and the fastener as well as the tightening process. This is because the torque is used to overcome friction as well as generating load. The amount of friction will depend on all of these things. If these conditions are not followed during tightening, the joint will not be tightened correctly and the fastener may break.

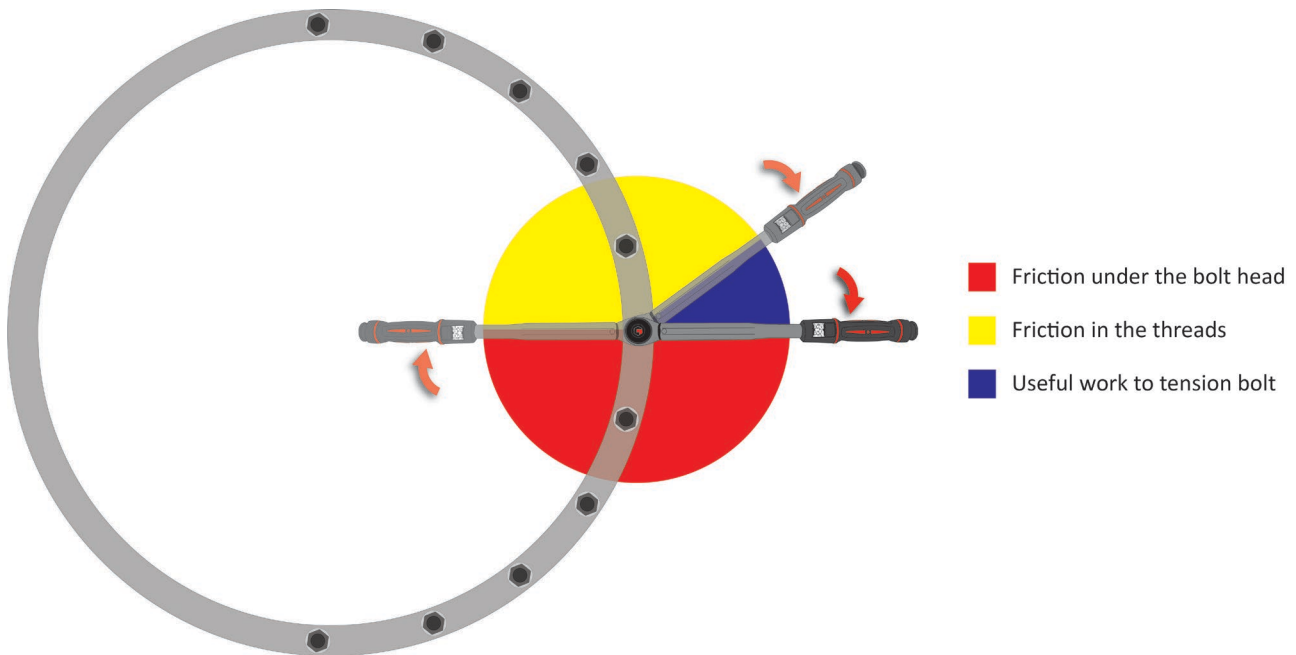

Let us look at the conditions that are important.

- **Quality of material:** The hardness, flatness, surface finish and protective coating are all important. Holes must be of the correct sizes and positioned accurately. They must be consistent and according to the technical specification. Problems here will change the amount of friction generated. Also, the material will deform or “creep” after tightening and this will reduce the clamp force. Soft materials normally deform more than hard ones. Surfaces that are not flat or that have rough surfaces will distort and reduce the clamp force more than smooth flat surfaces.
- **Quality of fastener:** The hardness, straightness, thread quality, surface finish and protective coating are also of importance for the fastener. Straightness, thread quality and coating are main causes of increased friction. Hardness will affect the “creep” after tightening.
- **Lubrication:** This is a critical factor. A bolt with graphite or molybdenum disulphide lubrication can reach three times the clamp force of a bolt with no lubrication for the same torque. This may result in the bolt stretching or even breaking. The design conditions must be followed to achieve the design clamp load.
- **Tightening tool:** We will discuss this in more detail in the next section but this should be the one thing that it is easy to control. The tool must be selected to give the correct speed of tightening. Too fast and the joint will not be properly clamped. It will loosen soon after tightening due to torsional relaxation of the fastener.
- **Relaxation:** Relaxation in the first hours will happen if the material creeps because it is too soft, or the bolt stretches because it is too soft, or high spots on the thread surface smooth out. These problems can be avoided by proper processes and quality control of components.

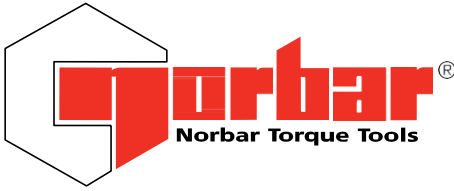

Norbar Torque Tools Ltd
 Wildmere Road | Banbury | Oxfordshire OX16 3JU | UK
 T +44 (0)1295 270333 | F +44 (0)1295 753609
 E enquiry@norbar.com | www.norbar.com

- Operator: The operator must understand why consistent operation is important. Education on basic bolting practice is important and should be delivered by appropriate people. There should be a specification for the process that defines the need for visual inspection of materials and fasteners, the bolt tightening order, the lubrication, and the operation of the tightening tool.

		Surface Condition of Bolt			
Surface Condition of Nut		Untreated	Zinc	Cadmium	Phosphate
	Untreated	1.00	1.00	0.80	0.90
	Zinc	1.15	1.20	1.35	1.15
	Cadmium	0.85	0.90	1.20	1.00
	Phosphate and oil	0.70	0.65	0.70	0.75
	Zinc with wax	0.60	0.55	0.65	0.55

Selection of the correct torque tool

The type of torque tool to be used will depend on the requirements for the joint. There are different levels of control and recording which will depend on the design requirements. Let us look at these requirements:

- Amount of damage caused by failure: If the failure of the joint will cause the death or injury of people then it is important. On automobiles there are many such joints, including the tightening of wheels onto the axle. If the failure will be expensive to repair then it is important. A large diesel engine can cost many thousands of dollars to repair if one bearing cap bolt becomes loose in service.
- Probability of failure: If the use of the product generates vibration, such as an engine, or changes in temperature such as a steam turbine, or pressure changes such as a pipeline, then the joint can loosen if it does not have enough clamp load initially.
- Customer expectation: Customers now expect increased reliability of all products from mobile phones to trains. Part of this reliability comes from the strength of the bolted assembly and so it must be properly tightened.
- Level of stress in fastener: The continuous demand of customers is for smaller, lighter, cheaper products. This means that fasteners are being reduced in size and in quantity per assembly. The fasteners that are left have to be more accurately tightened to maintain the quality.
- Level of stress in materials: The use of plastic parts for modern consumer electronics means that screws are often tightened into plastic. This creates many different problems of joint strength and creep.



Norbar Torque Tools Ltd

Wildmere Road | Banbury | Oxfordshire OX16 3JU | UK

T +44 (0)1295 270333 | F +44 (0)1295 753609

E enquiry@norbar.com | www.norbar.com

- Volume of joints being tightened: The requirements of an assembly line are different to the repair workshop. The differences will include the time allowed for a tightening operation, the number of fasteners to tighten per day, the amount of investment available and the quality control requirements.
- Quality Control requirements: This will depend on the company policies and will vary depending on some of the above factors. For example, a company may accept tightening by manual torque wrench on some joints. Others may require a second test with electronic wrench which records the reading. The most important joints may have torque-controlled tools which record the torque achieved on every fastener and tell the operator if there is a problem.
- Access to fasteners: The designers must think about the ability to tighten the joint. It can happen that a special design of tool is required to achieve the design torque because standard tools are not able to fit onto the fastener.