

Pneutorque® Remote Control Standard Series

All Standard and Small Diameter Series Pneutorques are available fitted with the remote motor.

- Stall control gives repeatability of $\pm 5\%$ on a given joint.
- Torque transducers and angle encoders available for all models. These form the basis of sophisticated control systems giving repeatability of up to $\pm 2\%$. See page 83.
- Automatic Two Speed gearbox reduces run-down times.
- Each gearbox supplied with a standard reaction device or, on request, one specifically designed to suit the application.

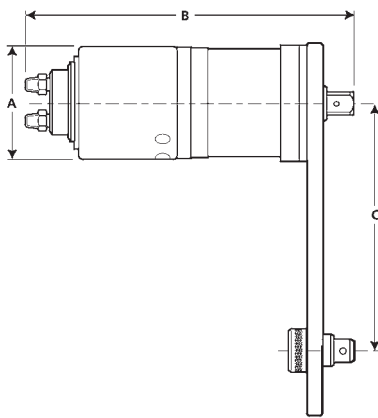

PT2 Remote



Standard Series, Remote Control

| Model | Square Drive | Part No. | Range | | Free Speed† | A | B | C min | C max | Tool Weight | Reaction Weight |
|-----------|--------------|------------|----------|----------|-------------|-----|-----|-------|-------|-------------|-----------------|
| | in | | N.m | lbf.ft | | | | | | | |
| PT 1 | 3/8 | 16031.X | 160-680 | 120-500 | 30 | 108 | 292 | 83 | 217 | 10.6 | 2.2 |
| PT 1 AUT | 3/8 | 16031.XAUT | 160-680 | 120-500 | 150 | 108 | 361 | 83 | 217 | 14.1 | 2.2 |
| PT 1 | 1 | 16011.X | 160-680 | 120-500 | 30 | 108 | 298 | 83 | 217 | 10.6 | 2.2 |
| PT 1 AUT | 1 | 16011.XAUT | 160-680 | 120-500 | 150 | 108 | 366 | 83 | 217 | 14.1 | 2.2 |
| PT 1A | 1 | 16097.X | 270-1200 | 200-900 | 15 | 108 | 298 | 83 | 217 | 11.1 | 2.2 |
| PT 1A AUT | 1 | 16097.XAUT | 270-1200 | 200-900 | 75 | 108 | 366 | 83 | 217 | 14.6 | 2.2 |
| PT 2 | 1 | 16013.X | 515-1700 | 380-1250 | 9 | 108 | 298 | 83 | 217 | 11.1 | 2.2 |
| PT 2 AUT | 1 | 16013.XAUT | 515-1700 | 380-1250 | 45 | 108 | 366 | 83 | 217 | 14.6 | 2.2 |
| PT 5 | 1 | 16015.X | 880-3400 | 650-2500 | 5 | 119 | 348 | 86 | 264 | 14 | 2.5 |
| PT 5 AUT | 1 | 16015.XAUT | 880-3400 | 650-2500 | 25 | 119 | 417 | 86 | 264 | 17.5 | 2.5 |

†Speed at maximum air pressure and in high gear where applicable.