



# Innovative Tools and Technology



2022 CATALOGUE  
ISSUE 1

In association with







# CONTENTS

About FASTORQ .....	3
Introduction to Torque .....	4
SpinTORQ 360° Continuously Rotating Torque Wrench .....	9
SpinTORQ Hydraulic .....	10
SpinTORQ Pneumatic .....	12
AutoTORQ Hydraulic Chain Pipe Wrench .....	13
AutoSPREADER Flange Spreader .....	15
AutoSPLITTER Hydraulic Nut Splitters .....	17

# LEGEND

## INDUSTRY

 Wind Energy	 Subsea
 Petrochemical	 Offshore
 Nuclear	 Mining
 Manufacturing	







## ABOUT FASTORQ



### ABOUT FASTORQ

FASTORQ, based in New Caney, Texas, is a preferred global provider of precision bolt loading and removal solutions. FASTORQ is a pioneer of the hydraulic tools industry and today designs, manufactures, and sells an innovative line of bolting solutions. FASTORQ has a complete line of hydraulic, electric and pneumatic tools, as well as design resources to customize existing tools or create one-of-a-kind bolting solutions. Rely on FASTORQ products for productivity, durability, safety and cost effective performance.

With over 100 combined years of bolting technology experience, FASTORQ designs, manufactures, tests and calibrates precision crafted tools that are easy to use and maintain. FASTORQ's highly skilled team of engineers and bolting technicians deliver timely resolution to bolting challenges of all sizes on land or sea. FASTORQ customers include a wide range of industrial applications: Subsea Construction, Oil & Gas Services, Petrochemical, Refinery, Power Generation (fossil fuel, nuclear, wind turbine and hydro-electric), Oil & Gas Drilling & Exploration, Pipeline Construction & Maintenance, Pulp & Paper, Mining, Heavy Equipment and Aerospace.

### FOUNDING AND MANAGEMENT

George A. Sturdevant founded FASTORQ in 1981 and has over 40 years of experience in design and manufacturing of hydraulic tools. Mr. Sturdevant helped design and market the first hydraulic torque wrench in 1972 and is a recognized authority on bolting technology and a contributor to a comprehensive educational textbook entitled the Handbook of Bolts and Bolted Joints. In 2011, ownership of FASTORQ changed to include new owners Mark Murphy (President) and Bill Washington (CEO). Bill Washington was with FASTORQ from 1992 to 1999 and is now Director of Business Development for the company.

On January 31, 2018, Snap-on Incorporated acquired FASTORQ. The acquisition of the FASTORQ product line complemented and increased Snap-on's existing torque product offering and broadened its established capabilities in serving in critical industries. As of January 1, 2020, FASTORQ has become part of the Norbar Group, a wholly owned subsidiary of Snap-on.

### SALES

FASTORQ products are sold through the company's sales force as well as domestic and international distributors. More information about the company is available at [www.fastorq.com](http://www.fastorq.com). FASTORQ provides customized tools for your applications. Call us!



## INTRODUCTION TO TORQUE

### What is Torque?

Torque is any force or system of forces that tends to cause rotation about an axis.

### Measurement of Torque

Imagine someone tightening a bolt using a socket attached to a meter (m) long bar. If they apply 10 kg of force (kgf) perpendicular to the bar they will produce a torque of 10 kgf·m at the axis (the centre of the bolt).

However, under the S.I. system of measurement, force is expressed in Newtons (N) rather than kgf. The conversion between kgf and N is x 9.807 so the person is applying 98.07 N·m of torque.

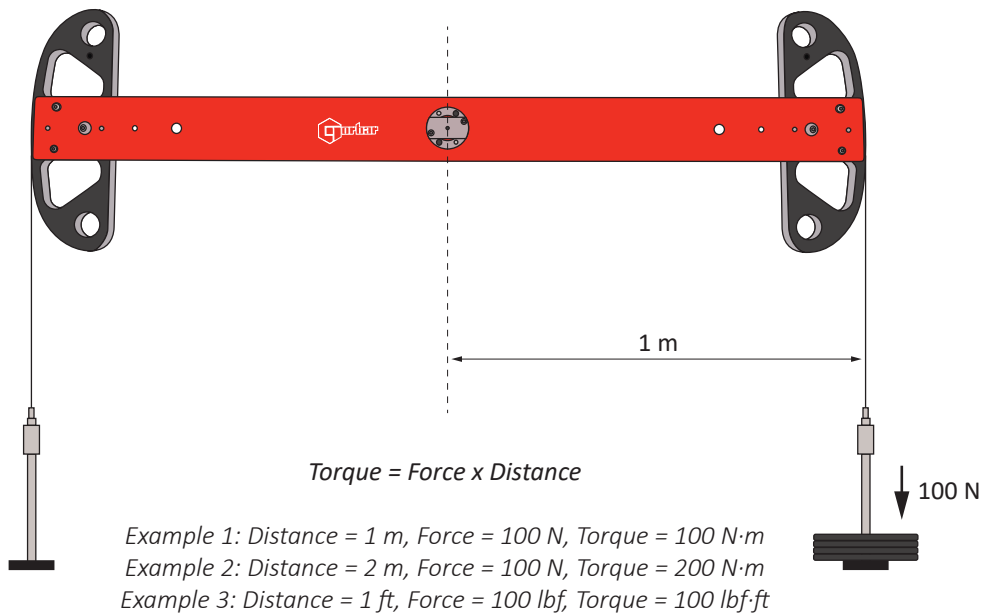

### The Importance of Torque Control

Although many methods exist to join two or more parts together, the ease of assembly and disassembly provided by threaded fasteners make them the ideal choice for many applications.

The object of a threaded fastener is to clamp parts together with a tension greater than the external forces tending to separate them. The bolt then remains under constant stress and is immune from fatigue. However, if the initial tension is too low, varying loads act on the bolt and it will quickly fail. If the initial tension is too high, the tightening process may cause bolt failure. Reliability therefore depends upon correct initial tension. The most practical way of ensuring this is by specifying and controlling the tightening torque.

### Bolt Tension

When an assembly is clamped by tightening a nut and bolt, the induced tension causes the bolt to stretch. An equal force acts to compress the parts which are thus clamped.

The proof load of a bolt, normally established by test, is the load which just starts to induce permanent set – also known as the yield point. Typically structural joints are tightened to between 75% and 90% of yield.

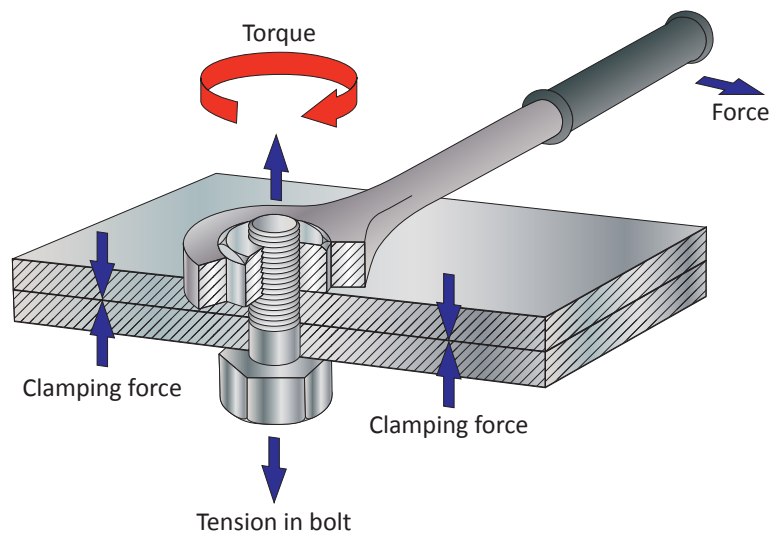



**INTRODUCTION TO TORQUE**

**Friction in the Bolted Joint**

When a threaded fastener is tightened, the induced tension results in friction under the head of the bolt and in the threads. It is generally accepted that as much as 50% of the applied torque is expended in overcoming friction between the bolt head and the abutting surface and another 30% to 40% is lost to friction in the threads. As little as 10% of the applied torque results in useful work to tension the bolt.

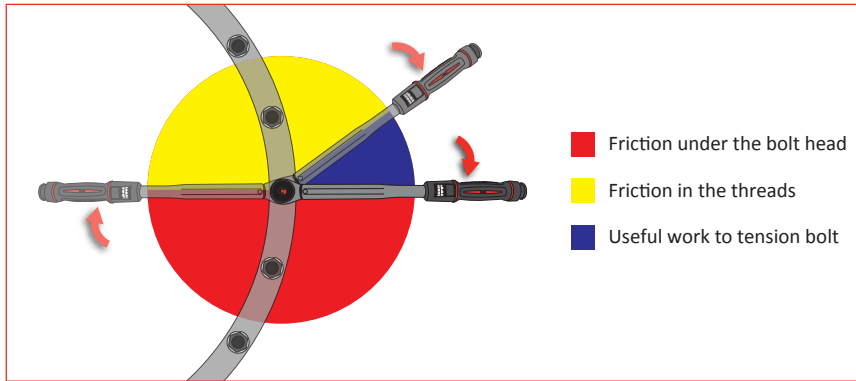

Given that up to 90% of the applied torque will be lost to friction, it follows that any changes in the coefficient of friction resulting from differences in surface finish, surface condition and lubrication can have a dramatic effect on the torque versus tension relationship. Some general points can be made:

- Many torque tightened joints do not use washers because their use can result in relative motion between the nut and washer or the washer and joint surface during tightening. This has the effect of changing the friction radius and hence affects the torque-tension relationship. Where a larger bearing face is required then flange nuts or bolts can be used. Washers can provide a benefit in certain situations by reducing friction and embedment into flange surfaces. Where washers are used, hard washers with a good fit to the shank of the bolt give lower and more consistent friction and are generally to be preferred.
- Degreasing fasteners of the film of oil usually present on them as supplied will decrease the tension for a given torque and may result in shear of the fastener before the desired tension is achieved.
- Super lubricants formulated from graphite, molybdenum disulphide and waxes result in minimal friction. Unless allowance is made in the specified tightening torque, the induced tension may be excessive causing the bolt to yield and fail. However, used in a controlled manner, these lubricants serve a useful purpose in reducing the torque to produce the desired tension meaning that a lower capacity tightening tool can be used.
- For reasons of appearance or corrosion resistance, fasteners may be plated. These treatments affect the coefficient of friction and therefore the torque versus tension relationship.
- Friction is often deliberately introduced into the fastener to reduce the possibility of loosening due to vibration. Devices such as lock-nuts must be taken into account when establishing the correct tightening torque.

As a rough guide, the calculated tightening torque should be multiplied by the factor from the table below according to surface

		Surface Condition of Bolt			
		Untreated	Zinc	Cadmium	Phosphate
Surface Condition of Nut	Untreated	1.00	1.00	0.80	0.90
	Zinc	1.15	1.20	1.35	1.15
	Cadmium	0.85	0.90	1.20	1.00
	Phosphate and oil	0.70	0.65	0.70	0.75
	Zinc with wax	0.60	0.55	0.65	0.55



## INTRODUCTION TO TORQUE

### Tightening to Yield

Structural bolts tightened to yield provide consistently higher preloads from smaller diameter bolts. The reduced fastener stiffness reduces the fatigue loading to which the bolt is subjected under repeated external load reversals, e.g. cylinder heads and connecting rods.

In theory, a bolt tightened to its yield point will provide the strongest and most fatigue-resistant joint possible, within the physical limitations of the bolt material and manufacturing process.

The downside of this method is the cost of the sophisticated equipment necessary to determine when the bolt goes into yield.

### Torque Tension Calculator

For further information and guidance on establishing the correct tightening torque for a fastener, see Norbar's web based calculator, [www.norbar.com/Support/Calculators/Torque-Tension-Calculator](http://www.norbar.com/Support/Calculators/Torque-Tension-Calculator)



### When Torque Doesn't Equal Tight

As we have established, it is the tension in a fastener rather than the torque that is the critical factor. Torque is an indirect means of establishing tension and in a correctly engineered joint and with a controlled tightening process, it is a satisfactory method under the majority of circumstances.

However, in joints that are highly critical due to safety or the cost and implications of machine down-time, a more direct means of establishing tension is needed. Various methods exist including several types of load indicating bolts or washers. However, one of the most versatile methods is to measure the extension of the bolt due to the tightening process using ultrasound.

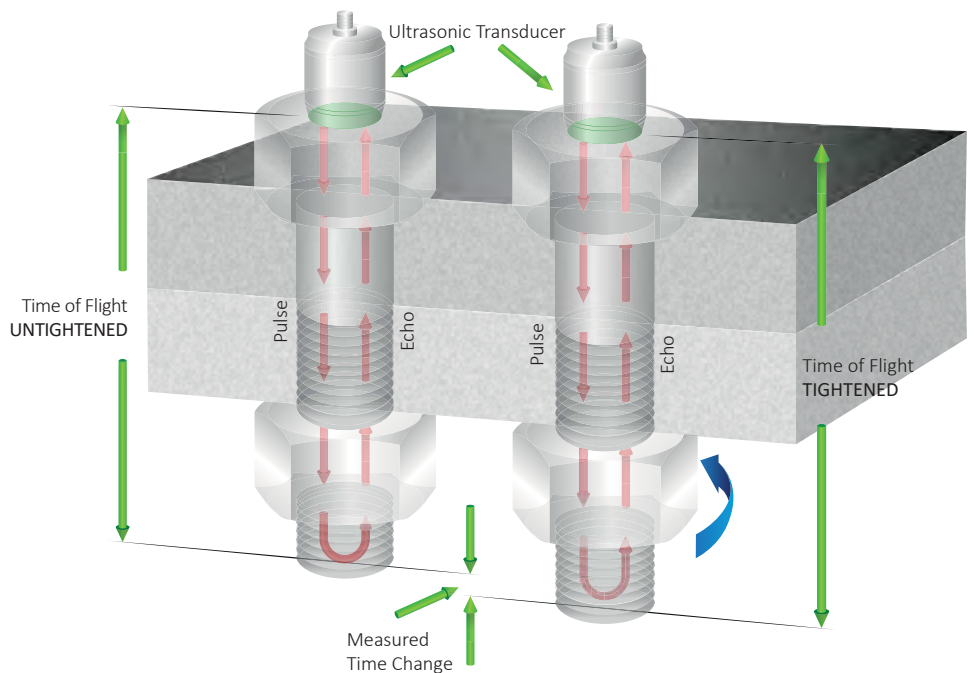



## INTRODUCTION TO TORQUE

### Torque Estimating Chart

ASTM A193, Grade "B7" Studs | Lubricant: Moly Paste | Nut Factors (K): 0.14, 0.18 or 0.20

Torque Values calculated using mechanical engineering "short formula"

$$T = K (\text{Nut Factor}) \times \text{Clamp Load (lbs)} \times \frac{D (\text{Bolt Diameter - Inches})}{12}$$

12

Stud Diameter (Inches)	Nut Size (ATF)	Torque Values (ft-lbs)								
		40% Yield			50% Yield			60% Yield		
		K=.14	K=.18	K=.20	K=.14	K=.18	K=.20	K=.14	K=.18	K=.20
½	⅞	35	45	50	43	56	62	52	67	75
⅝	1 <sup>1</sup> / <sub>16</sub>	69	89	99	87	111	124	104	134	148
¾	1¼	123	158	175	153	197	219	184	237	263
⅞	1 <sup>7</sup> / <sub>16</sub>	198	255	283	248	318	354	297	382	424
1	1 <sup>5</sup> / <sub>8</sub>	297	382	424	371	477	530	445	573	636
1 <sup>1</sup> / <sub>8</sub>	1 <sup>13</sup> / <sub>16</sub>	435	560	622	544	700	778	653	840	933
1¼	2	613	788	875	766	984	1,094	919	1,181	1,313
1 <sup>3</sup> / <sub>8</sub>	2 <sup>3</sup> / <sub>16</sub>	831	1,068	1,187	1,038	1,335	1,483	1,245	1,602	1,780
1½	2 <sup>3</sup> / <sub>8</sub>	1,097	1,410	1,567	1,371	1,762	1,958	1,645	2,115	2,350
1 <sup>5</sup> / <sub>8</sub>	2 <sup>9</sup> / <sub>16</sub>	1,417	1,822	2,025	1,772	2,278	2,531	2,126	2,733	3,037
1¾	2¾	1,784	2,293	2,548	2,230	2,867	3,185	2,675	3,440	3,822
1 <sup>7</sup> / <sub>8</sub>	2 <sup>15</sup> / <sub>16</sub>	2,214	2,847	3,163	2,768	3,559	3,954	3,321	4,270	4,745
2	3 <sup>1</sup> / <sub>8</sub>	2,715	3,490	3,878	3,393	4,090	4,848	4,072	5,235	5,817
2¼	3½	3,925	5,046	5,607	4,906	6,308	7,009	5,887	7,569	8,411
2½	3 <sup>7</sup> / <sub>8</sub>	4,921	6,327	7,030	6,151	7,909	8,788	7,382	9,491	10,545
2¾	4¼	6,620	8,512	9,457	8,275	10,639	11,822	9,930	12,767	14,186
3	4 <sup>5</sup> / <sub>8</sub>	8,658	11,132	12,369	10,823	13,915	15,461	12,987	16,698	18,554
3¼	5	11,080	14,246	15,829	13,850	17,807	19,786	16,620	21,369	23,743
3½	5 <sup>3</sup> / <sub>8</sub>	13,903	17,875	19,861	17,379	22,344	24,827	20,854	26,813	29,792
3¾	5¾	17,190	22,102	24,558	21,488	27,627	30,697	25,785	33,153	36,836
4	6 <sup>1</sup> / <sub>8</sub>	20,943	26,927	29,919	26,179	33,659	37,398	31,415	40,390	44,878

#### Material Yield Strength:

½" - 2¼" Diameter Studs: 105,000 PSI

2½" - 4" Diameter Studs: 95,000 PSI

#### Number of Threads:

½" Diameter Studs: 13 TPI ⅞" Diameter Studs: 9 TPI

⅝" Diameter Studs: 11 TPI 1" - 4" Diameter Studs: 8 TPI

¾" Diameter Studs: 10 TPI

**The K Factor is an experimentally determined constant that relates the torque applied to the load induced in the fastener. This factor is affected by the condition of the fastener, the lubricant used and the condition of the flange.**

For example, the 0.18 K Factor listed above is based on the following conditions:

- New condition of flanges, studs and nuts.
- Thorough application of lubricant on all mating surfaces of flange, nut and stud.
- Use of hardened steel washers.





INTRODUCTION TO TORQUE

Torque Conversion Factors

Units to be converted	S.I. Units		Imperial Units			Metric Units	
	cN·m	N·m	ozf·in	lbf·in	lbf·ft	kgf·cm	kgf·m
1 cN·m =	1	0.01	1.416	0.088	0.007	0.102	0.001
1 N·m =	100	1	141.6	8.851	0.738	10.20	0.102
1 ozf·in =	0.706	0.007	1	0.0625	0.005	0.072	0.0007
1 lbf·in =	11.3	0.113	16	1	0.083	1.152	0.0115
1 lbf·ft =	135.6	1.356	192	12	1	13.83	0.138
1 kgf·cm =	9.807	0.098	13.89	0.868	0.072	1	0.01
1 kgf·m =	980.7	9.807	1389	86.8	7.233	100	1

**FORCE**  
 lbf x 4.45 = N  
 N x 0.225 = lbf

**FLOW**  
 l/s x 2.119 = cu·ft/min  
 cu·ft/min x 0.472 = l/s

**PRESSURE**  
 lbf/in<sup>2</sup> x 0.069 = bar  
 bar x 14.504 = lbf/in<sup>2</sup>

**POWER**  
 hp x 0.746 = kW  
 kW =  $\frac{N \cdot m \times rev/min}{9,546}$

Formulae

Accepted formulae relating torque and tension, based on many tests are:-

For Imperial Sizes

$$M = \frac{P \times D}{60}$$

M = torque lbf·ft  
 P = bolt tension lbf  
 D = bolt diameter (ins)

For Metric Sizes

$$M = \frac{P \times D}{5000}$$

M = torque N·m  
 P = bolt tension Newtons  
 D = bolt diameter (mm)

These formulae may be used for bolts outside the range of the tables.

Formula for Calculating the Effect of Torque Wrench Extensions

$$M1 = M2 \times L1/L2$$

Where L1 is the normal length and L2 is the extended length, M1 is the set torque and M2 the actual torque applied to the nut.

Example

The required torque on the fastener is 130 N·m (M2) but what do you set on the torque wrench scale?

L1 = 500      L2 = 650  
 (units of length not important, this is ratio)

$$M1 = 130 \times 500/650$$

$$M1 = 100$$

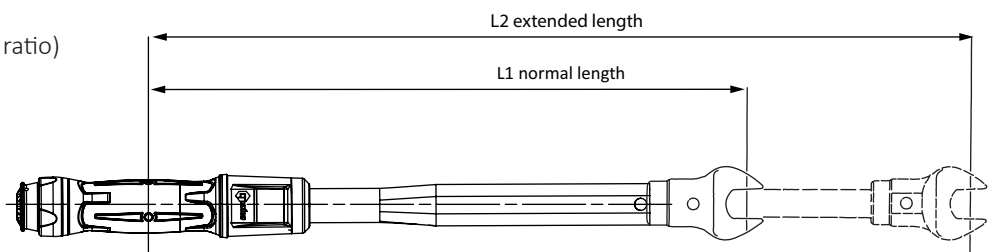

For further information and guidance on converting torque and calculating the effect of torque wrench extensions download our purpose-built applications for iPhone and Android.

## SPINTORQ 360° CONTINUOUSLY ROTATING TORQUE WRENCH

There's only one like it in the world!

When speed matters, only one torque wrench blows all the others out of the water: SpinTORQ.

SpinTORQ is the only low-profile, continuously rotating torque wrench available today. It provides 360-degree continuous rotation, faster at turning a nut than ratcheting hydraulic wrenches. Pair this speed with SpinTORQ's ability to deliver full power in both forward and reverse, and you have dramatic time saving benefits.

Ratcheting hydraulic wrenches only rotate the nut 10 to 15 degrees for each extension of the cylinder. Each time the cylinder extends, the power unit must build pressure. This tedious process makes turning a nut a very slow ordeal. SpinTORQ's hydraulic and pneumatic model, with their continuous turn, build pressure one time!

A specially designed, double-enveloping worm gear gives SpinTORQ the power to get the job done fast. SpinTORQ never locks up and is removed with ease.

- Full power forward and reverse
- Hydraulic and pneumatic models available
- Patented design
- Fits tight spaces
- Custom sizes available



**SPINTORQ HYDRAULIC**

**Applications and Specifications**

Everyone knows that dive time is expensive. A subsea flange that normally takes two hours to make-up with a hydraulic ratcheting wrench can be completed in less than 30 minutes with the SpinTORQ!

The SpinTORQ is a game changer in shutdown/turnaround situations where multiple ranges must be bolted and equipment needs hydrostatic testing to bring a unit back online. SpinTORQ has the power to bring any unit back online a full day or more earlier than scheduled. This can easily add up to millions of dollars in profit!

SpinTORQ's 2,500 psi system easily adapts to ROVs without the use of a hydraulic hose down line.

The durable steel body and the dependability of the FASTORQ Total Assurance Guarantee ensure you not only get innovation but reliability when you purchase a SpinTORQ. All SpinTORQ models are covered for one year with the added benefit of free warranty extension with our annual free inspection and calibration program.

In addition to the 10 standard models, FASTORQ engineers will design and custom build SpinTORQ wrenches to meet a customer's specific requirements.

Don't let ratcheting hydraulic torque wrenches slow your project down any longer. Save time and money with SpinTORQ.

The 2,500 psi. hydraulic system allows the SpinTORQ Hydraulic Torque Wrench to be connected to an ROV or rig hydraulic source. It also eliminates the need for slow and problematic 10,000 psi. power units. The lower operating pressure is also a safety benefit.

WRENCH HEAD MODEL	MOTOR MODEL	TORQUE RANGE	£
HST360113	IL360M2	1 13/16" Hex, 272 - 950 N·m, 200 - 700 ft·lb	TBC
HST360200		2" Hex, 272 - 1,220 N·m, 200 - 900 ft·lb	TBC
HST360203		2 3/16" Hex, 407 - 1,627 N·m, 300 - 1,200 ft·lb	TBC
HST360206		2 3/8" Hex, 543 - 2,170 N·m, 400 - 1,600 ft·lb	TBC
HST360209	IL360M4	2 9/16" Hex, 814 - 2,983 N·m, 600 - 2,200 ft·lb	TBC
HST360212		2 3/4" Hex, 1,085 - 3,797 N·m, 800 - 2,800 ft·lb	TBC
HST360215		2 15/16" Hex, 1,356 - 4,601 N·m, 1,000 - 3,000 ft·lb	TBC
HST360302		3 1/8" Hex, 1,627 - 5,424 N·m, 1,200 - 4,000 ft·lb	TBC
HST360308	IL360M5	3 1/2" Hex, 1,900 - 6,780 N·m, 1,400 - 5,000 ft·lb	TBC
HST360314		3 7/8" Hex, 2,848 - 9,491 N·m, 2,100 - 7,000 ft·lb	TBC

**Applications**

- Subsea Bolting
- Nuclear Flange Maintenance
- Topside BOP Bolting
- Plate, Shell and Tube Heat Exchangers
- Critical Path Bolted Connections





SPINTORQ HYDRAULIC



Model	SpinTORQ Hydraulic										
Part Number	HST360113	HST360200	HST360203	HST360206	HST360209	HST360212	HST360215	HST360302	HST360308	HST360314	
Dimensions (mm)	A	394	394	406	448	470	470	483	483	547	547
	B	248	261	93	299	324	323	337	337	356	356
	C	93	93	93	93	93	93	96	96	102	102
	D	84	84	83	84	84	84	84	84	84	84
	E	34	39	39	48	51	51	58	61	63.5	64
	F	99	127	127	143	156	156	166	185	204	204
	G	36	48	48	51	58	58	59	70	77	77
	H	1 <sup>13</sup> / <sub>16</sub>	2	2 <sup>3</sup> / <sub>16</sub>	2 <sup>3</sup> / <sub>8</sub>	2 <sup>9</sup> / <sub>16</sub>	2 <sup>3</sup> / <sub>4</sub>	2 <sup>15</sup> / <sub>16</sub>	3 <sup>1</sup> / <sub>4</sub>	3 <sup>1</sup> / <sub>2</sub>	3 <sup>7</sup> / <sub>8</sub>
Hex Head Weight (kg)	2.3	2.9	2.9	5.4	7.0	6.6	8.2	10.5	12.7	12.7	
Motor Weight (kg)	4.7	4.7	4.7	4.7	5.3	5.3	5.3	5.3	7.4	7.4	



**603A**

2,500 psi. high flow air motor driven hydraulic power unit. Oil delivery is 7 gal./min. Requires 100 psi. @ 150 scfm. Input air.



**603E**

2,500 psi. high flow electric motor driven hydraulic power unit. Oil delivery is 14 gal./min. Requires 480V, 3-phase, 60 Hz. input power.



**ST-CU**

2,500 psi. hydraulic control unit. Allows rig hydraulics or other hydraulic power source to be used with SpinTORQ Hydraulic Model.

**SPINTORQ PNEUMATIC**



When hydraulic oil becomes a problem on the job site or in a shop environment, the solution is the SpinTORQ Pneumatic Torque Wrench. It eliminates the mess of hydraulic fluid and the requirement for a separate power supply.

Torque is set by use of the regulator on an Filter, Regulator and Lubricator unit (FRL)

**Features and Benefits**

- Low-profile head continuously rotates 360 degrees in forward and reverse, reducing time spent torquing fasteners, while allowing the wrench to operate in very limited access bolting applications
- Accuracy of applied torque is  $\pm 5\%$
- Wrench head can be indexed independently from the tool's gearbox, allowing the handle to be ergonomically positioned during operation
- Fit and reaction points are designed to standard ANSI and API piping flange dimensions, so the tool rests against adjacent nuts during use
- Robust design combines a well proven and highly efficient epicyclical gearbox with a double enveloping worm gear drive to provide reliable and repeatable performance
- Durable powder coating is ideal for demanding work environments

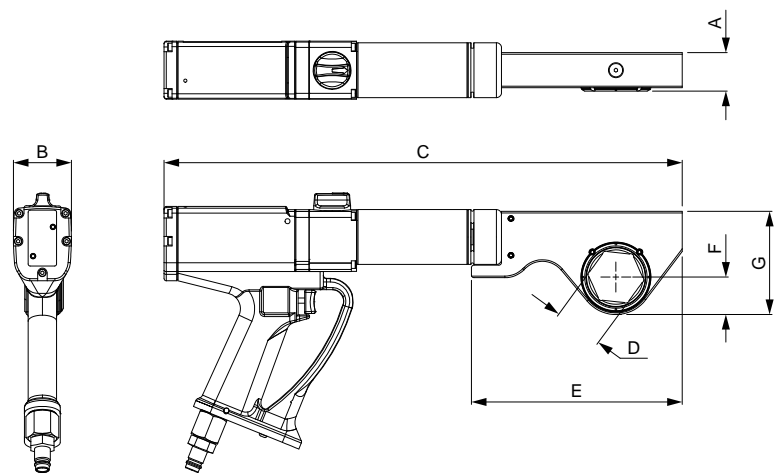
WRENCH HEAD MODEL	MOTOR MODEL	TORQUE RANGE	£
PST686H113	PSTM77517	1 <sup>13</sup> / <sub>16</sub> " Hex, 186 - 930 N·m, 140 - 686 ft·lb	TBC
PST953H200		2" Hex, 259 - 1,292 N·m, 190 - 953 ft·lb	TBC
PST1281H203		2 <sup>3</sup> / <sub>16</sub> " Hex, 348 - 1,737 N·m, 256 - 1,281 ft·lb	TBC
PST1677H206	PSTM77514	2 <sup>3</sup> / <sub>8</sub> " Hex, 455 - 2,274 N·m, 335 - 1,677 ft·lb	TBC
PST2146H209		2 <sup>9</sup> / <sub>16</sub> " Hex, 582 - 2,910 N·m, 430 - 2,146 ft·lb	TBC
PST2696H212		2 <sup>3</sup> / <sub>4</sub> " Hex, 731 - 3,655 N·m, 540 - 2,696 ft·lb	TBC
PST3332H215	PSTM77519	2 <sup>15</sup> / <sub>16</sub> " Hex, 903 - 4,518 N·m, 666 - 3,332 ft·lb	TBC
PST4061H302		3 <sup>1</sup> / <sub>8</sub> " Hex, 1,101 - 5,506 N·m, 812 - 4,061 ft·lb	TBC



Model	SpinTORQ Pneumatic								
Part Number	PST686H113	PST953H200	PST1281H203	PST1677H206	PST2146H209	PST2696H212	PST3332H215	PST4061H302	
Dimensions (mm)	A	33	42	42	46	51	51	57	61
	B	55	55	55	55	55	55	55	55
	C	495	522	522	538	558	558	562	581
	D	46	52	56	61	66	71	75	80
	E	203	230	230	247	267	267	262	281
	F	36	47	47	51	57	57	58	70
	G	98	124	124	143	155	155	166	184
Weight (kg)	7.35	8.85	8.85	11.25	12.85	12.85	14.1	17.2	

## AUTOTORQ HYDRAULIC CHAIN PIPE WRENCH

The AutoTORQ Hydraulic Chain Pipe Wrench is specifically designed to be a portable solution to tighten and loosen threaded pipe connections. It replaces tongs and other manual methods for “making” and “breaking” these connections. It provides a safer and faster alternative to the hands-on set up of tongs and come-a-longs and helps eliminate more than half of the injuries on a rig and in shop environments.

With the press of a button, the AutoTORQ Hydraulic Chain Pipe Wrench allows the user to move away from the dangerous, and even deadly, radius around the pipe.

Available in five models, pipe make-up and break-out is a breeze. Just by latching the chain around the pipe and adjusting the slack with the tensioning nut, tightening and loosening of tubular threaded joints are no problem.

When used with the FASTORQ 610A Power Unit, FASTORQ’s five chain pipe wrench models provide maximum speed and torque output from 10,367 to 83,998 ft-lb.

In addition to its unmatched safety, the AutoTORQ Hydraulic Chain Pipe Wrench gives operators the portability to go anywhere it’s needed.

When compared to the lack of portability offered by tabletop models, there is no comparison.

- **Incredible safety benefits**
- **Portable & tough**
- **9,675 to 77,607 ft-lb of torque**
- **Pipe diameters from 1” to 14”**
- **6,000 psi operating pressure**

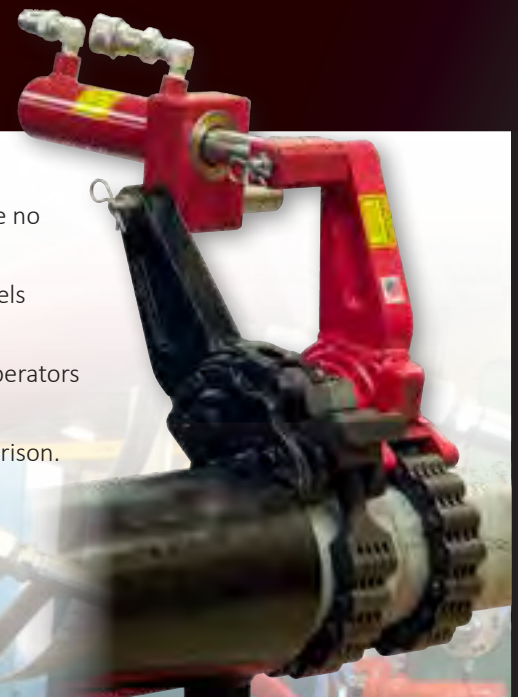



## AUTOTORQ HYDRAULIC CHAIN PIPE WRENCH



### The AutoTORQ Advantage

Competing products are tongs or products based on off-the-shelf tongs. Following are some of the advantages the AutoTORQ Hydraulic Chain Pipe Wrench has over these products.

**Safe** - Once the AutoTORQ is set up on the pipe, the operator stands a safe distance away from the tool and watches it do the work. Tongs are either operated by hand or with the assistance of some type of chain or cable with a mechanical or motorized winch. This is extremely dangerous as the cables or chains can break.

**Compact** - The AutoTORQ has wrench arms that are much shorter than tong handles allowing it to work in tight places.

**Stable** - The AutoTORQ is designed to maintain a secure footing on the pipe through the entire power stroke. Tongs are extremely prone to side loading making it difficult to break loose pipe connections requiring higher torque.

**Powerful** - The AutoTORQ has 20% or more torque output than competing tools.

**Portable** - The AutoTORQ is preferable to “bucking machines” that are not portable. It is also designed to be assembled on the pipe in pieces making it easier to handle.

**Low Profile Reaction Unit** - For piping connections with space restrictions, an optional Low Profile Reaction Unit is available. It incorporates ZipNut Technology for fast installations and removal on the pipe. Specific information available upon request.



PART NUMBER	PIPE OUTSIDE DIAMETER INCHES (mm)	MAXIMUM TORQUE lbf-ft (N·m)	£
PW1STR	1 to 6 (25-152)	10,367 (14,422)	TBC
PW2STR	2- <sup>1</sup> / <sub>8</sub> to 5 (54-127)	23,158 (31,398)	TBC
PW3STR	3 to 8- <sup>1</sup> / <sub>4</sub> (76-210)	24,380 (33,055)	TBC
PW4STR	4- <sup>1</sup> / <sub>4</sub> to 10- <sup>3</sup> / <sub>4</sub> (108-273)	46,620 (63,208)	TBC
PW5STR	8- <sup>1</sup> / <sub>8</sub> to 14 (102-356)	83,998 (113,886)	TBC

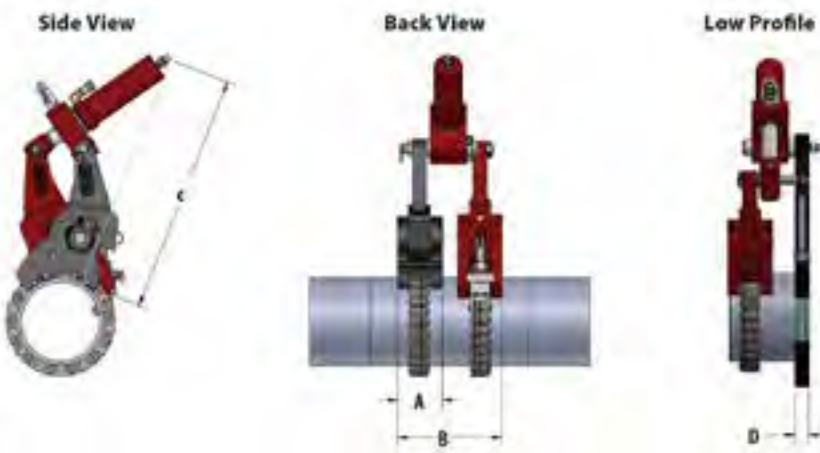

Model	AutoTORQ					
Part Number	PW1STR	PW2STR	PW3STR	PW4STR	PW5STR	
Dimensions (mm)	A	102	114	127	127	184
	B	210	235	260	260	400
	C	483	584	635	686	813
	D	45	51	51	68	89
Weight (kg)	27	52	62	86	159	



#### 610A

10,000 psi. high flow air driven hydraulic power unit delivers 470 in<sup>3</sup>/min. @ 0 psi. and 150 in<sup>3</sup>/min. @ 10,000 psi.



#### FHFA-10K

10,000 psi. compact air driven hydraulic power unit delivers 620 in<sup>3</sup>/min. @ 0 psi. and 62 in<sup>3</sup>/min. @ 10,000 psi.



#### FHFE-10K

10,000 psi. compact electric driven hydraulic power unit delivers 620 in<sup>3</sup>/min. @ 0 psi. and 62 in<sup>3</sup>/min. @ 10,000 psi.

## AUTOSPREADER FLANGE SPREADER

FASTORQ Manual AutoSPREADERs are simple to use. Just by placing the AutoSPREADER jaws between the flange faces and turning the ratchet handle, you get 10,000 lb of spreading force in one pass. AutoSPREADERs create up to a 3-inch gap with no slipping thanks to their serrated jaws. Perfect for lifting, leveling, lowering and aligning, AutoSPREADERs are a great choice when safety and strength are needed.

Pair the power of hydraulics with the versatility of the FASTORQ Hydraulic AutoSPREADER to get 10,000 lb of spreading force per flange spreader. Multiple spreaders can even be powered by just one standard hand pump. Each AutoSPREADER creates up to a 3-inch gap in a single pass and is perfect for lifting, leveling, lowering and aligning. With serrated jaws to provide security while spreading, FASTORQ's Hydraulic AutoSPREADERs are a smart choice when safety and strength are necessary.

- **10,000 lb of force per spreader**
- **Lightweight – only 13.5 lb**
- **3" gap achieved in a single pass**
- **Fast & easy**
- **Only requires a  $\frac{3}{16}$ " insertion gap**
- **Jaws open parallel**
- **No loose wedges or parts**
- **Safety blocks included**





# AUTOSPREADER FLANGE SPREADER



## AutoSPREADER Hydraulic Power Unit Model 150H2

2-stage hydraulic hand pump comes complete with (2) 12-foot hydraulic hoses, T-block and load-lowering valve. The load-lowering valve allows the operator to safely control the return of the flange spreaders. This configuration is expandable for more AutoSPREADERS with additional T-blocks and hoses.

Note: Motorized hydraulic power units are not recommended for use with the AutoSPREADER as the higher flow rate and resulting high rate of travel produced is not safe.

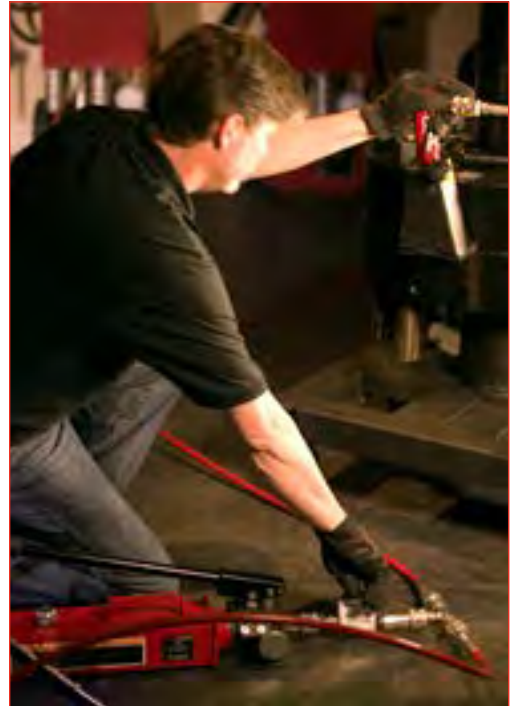

### UNIVERSAL:

- One Size Fits All Flange Sizes

### SAFE:

- No Loose Wedges or Parts
- Safety Blocks Included
- Can Be Remotely Operated
- No Drift- It Stays Put
- Jaws Open Parallel

### POWERFUL:

- 10,000 lbs of Force per Spreader

### SIMPLE OPERATION:

- Easy – One Person Operation
- Lightweight – Just 12 lbs

### VERSATILE:

- Gasket Maintenance
- Turning Blinds
- Separate Manways
- Open Vessels
- Bearing Removal
- Impeller Removal
- Lifting
- Levelling
- Lowering
- Aligning



Perfect for lifting, leveling, lowering and aligning, AutoSPREADER's are a great choice when safety and strength are needed

Model		AutoSPREADER	
Part Number		HS10K	MS10K
Dimensions (mm)	Length	355	336
	Width of Jaws	114	114
	Width of Body	114	114
	Jaws Closed	3.2	3.2
	Jaws Open	76.2	76.2
	Jaw Penetration	38.1	38.1
Weight (kg)		5.4	6.1

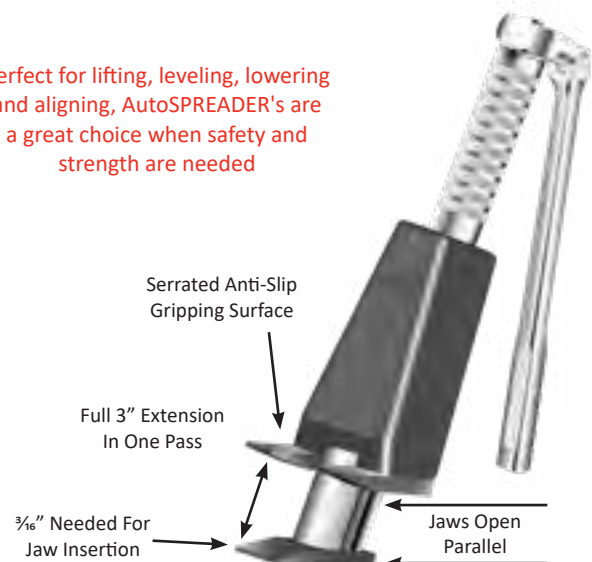



## AUTOSPLITTER HYDRAULIC NUT SPLITTERS

AutoSPLITTER can cut through the largest frozen nuts in just seconds, with virtually no risk of injury or accident. It's easy. Simply slip AutoSPLITTER head over the nut and apply hydraulic pressure. One cut frees even the most corroded nut so it can be turned. Or make two cuts, 180 degrees apart, to cleanly cut the nut away.

**FAST** - To remove a 3½" nut with a torch or hammer and chisel might take up to 20 minutes. But you only need 20-30 seconds with the AutoSPLITTER. Setup is fast as well. AutoSPLITTER goes from the toolbox to use in less than five minutes.

**SAFE** - No hammers or flame are used. The operator has hands off during operation. No hot work permits are required. AutoSPLITTER cuts smoothly so that there is no danger to the operator or the surrounding equipment.

**VERSATILE** - AutoSPLITTER cuts through even the hardest nuts, including ASTM A194 2H from 1¼" to 6½" (17- 156 mm) across the flats. You can use it for both inch and metric sizes, and with virtually any shape nut. Round, square, 12-point and other special nuts will require the use of an adapter. Competing nut splitters require up to 17 models to cover the same size range the AutoSPLITTER does in 9 models (and even as few as 4 models if the Duo and Trio packages are purchased)!

**QUIET** - All you'll hear is the hum of the hydraulic pump and a reassuring "snap" when the nut is cut. With AutoSPLITTER, there's no noise pollution or risk of noise related injury.

**PRECISE** - You can easily calibrate the cutting chisel so only the nut is cut, with no damage to the bolt or stud threads.

**MONEY SAVING** - Nut removal takes less time so downtime is reduced. With AutoSPLITTER, you can also avoid costly damage to bolts, studs and surrounding equipment.

**FLEXIBLE** - AutoSPLITTER is specially designed, so you can work from more angles and in more applications than with competing models. AutoSPLITTER fits all API and ANSI flanges and virtually all valve bonnets.

**DURABLE** - AutoSPLITTER is made to last. Our special metallurgy, geometry and hardening process make our chisels good for dozens of cuts before resharping and many resharpings before replacing! Because of its unique compound angle chisel design, the AutoSPLITTER even cuts stainless steel nuts! All AutoSPLITTER products come with FASTORQ's no hassle Lifetime Guarantee!

- Cuts through the hardest of nuts – quickly & safely
- Cuts more nut sizes per models than competitors
- Precision, re-sharpenable chisel cuts only the nut
- Perform dozens of cuts before chisel needs sharpening
- Double Cutting & Angle Head models also available





AUTOSPLITTER HYDRAULIC NUT SPLITTERS



Some jobs just call for speed. When time matters, double your performance with FASTORQ's Double Cutting Nut Splitter™.

Available in 1/16 inch to 4 1/4 inch cutting range, cutting across the flats just became faster and easier. The Double Cutting AutoSPLITTER works by eliminating the need to move the nut splitter to a second position 180 degrees from the first to break the nut from the stud! That's a serious time saving benefit.

Single Cut, Straight and Angled models also available.



PART NUMBER		STUD DIAMETER INCHES (METRIC)	NUT SIZE ATF INCHES (mm)	£
KITS	INDIVIDUAL			
ASDUO25AHDC	AS105AHDC	5/16 - 3/4 (M8-M20)	1 1/16 - 1 1/4 (16-36)	TBC
	AS200AHDC	7/8 - 1 1/8 (M22-M30)	1 7/16 - 1 11/16 (36-41)	TBC
ASDUO55AHDC	AS204AHDC	1 1/4 - 1 3/8 (M33-M36)	1 13/16 - 2 3/16 (46-60)	TBC
	AS210AHDC	1 3/8 - 1 1/2 (M36-M39)	2 3/16 - 2 3/8 (55-65)	TBC
ASDUO100AHDC	AS308AHDC	1 3/4 - 2 (M45-M52)	2 5/8 - 3 1/8 (65-90)	TBC
	AS314AHDC	2 - 2 1/4 (M52-M56)	3 - 3 5/8 (80-90)	TBC
	AS404AHDC	2 3/4 - 3 1/4 (M72-M85)	3 3/4 - 4 1/4 (95-110)	TBC

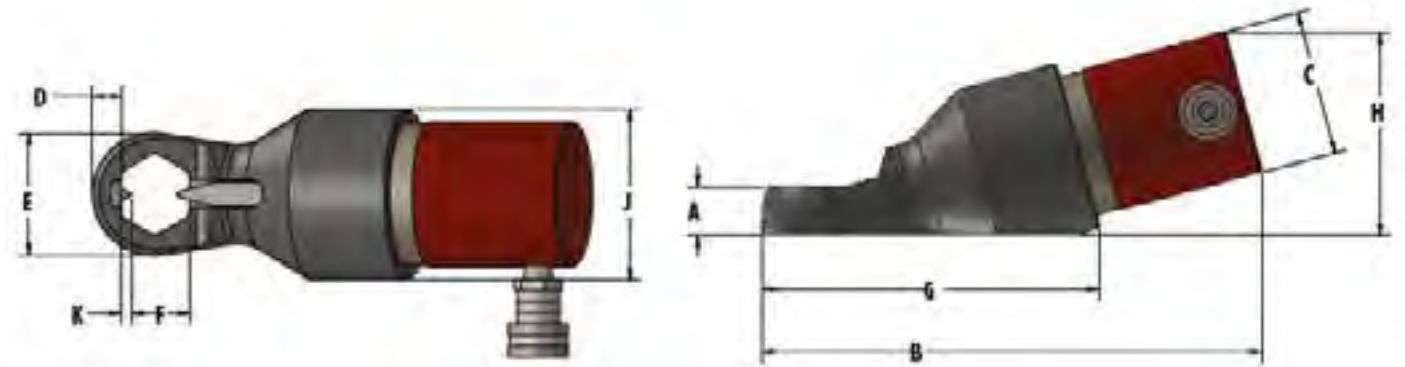

Model		AutoSPLITTER						
Part Number		AS105AHDC	AS200AHDC	AS204AHDC	AS210AHDC	AS308AHDC	AS314AHDC	AS404AHDC
Dimensions (mm)	A	29	35	45	51	64	70	95
	B	296	315	417	424	505	526	545
	C	86	86	127	127	159	159	216
	D	17	24	29	25	38	44	53
	E	73	92	114	121	160	171	197
	F	34	51	59	61	80	94	109
	G	201	218	313	320	362	380	400
	H	86	120	170	171	211	211	365
	J	101	101	149	152	184	187	240
	K	6	6	9	11	16	18	14
Weight (kg)		9	10	28	28	43	45	94

**AUTOSPLITTER HYDRAULIC NUT SPLITTERS**



**Power Units for AutoSPLITTER**

AutoSPLITTER products require 10,000 PSI hydraulic pump (sold separately). We supply electric, air and manually driven power units. When electricity or air power are not available, select Model 150H. With each pump you will receive 12 feet of hydraulic hose plus all fittings and quick disconnects needed.



**610A**

10,000 psi. high flow air driven hydraulic power unit delivers 470 in<sup>3</sup>/min. @ 0 psi. and 150 in<sup>3</sup>/min. @ 10,000 psi.



**FHFA-10K**

10,000 psi. compact air driven hydraulic power unit delivers 620 in<sup>3</sup>/min. @ 0 psi. and 62 in<sup>3</sup>/min. @ 10,000 psi.



**FHFE-10K**

10,000 psi. compact electric driven hydraulic power unit delivers 620 in<sup>3</sup>/min. @ 0 psi. and 62 in<sup>3</sup>/min. @ 10,000 psi.



**150H**

10,000 psi. 2-stage manual hydraulic power unit delivers 0.66 in<sup>3</sup>/min. @ 325 psi. and 0.16 in<sup>3</sup>/min. @ 10,000 psi.



**105A**

10,000 psi. air driven, foot actuated hydraulic power unit delivers 68 in<sup>3</sup>/min. @ 0 psi. and 4 in<sup>3</sup>/min. @ 10,000 psi.



## FASTORQ PRODUCT PORTFOLIO



## FASTORQ SOCIAL MEDIA



@FASTORQ1



Fastorq



FASTORQ



FASTORQ



18914 East Industrial Parkway  
New Caney, TX 77357  
UNITED STATES OF AMERICA

Main: 281.449.6466 | 1.800.231.1075

[esales@fastorq.com](mailto:esales@fastorq.com) | [www.fastorq.com](http://www.fastorq.com)



For Terms and  
Conditions of sale  
please visit the Norbar  
website or main  
Norbar catalogue