

13001 - TW MDL5 ADJ 1-5 Nm

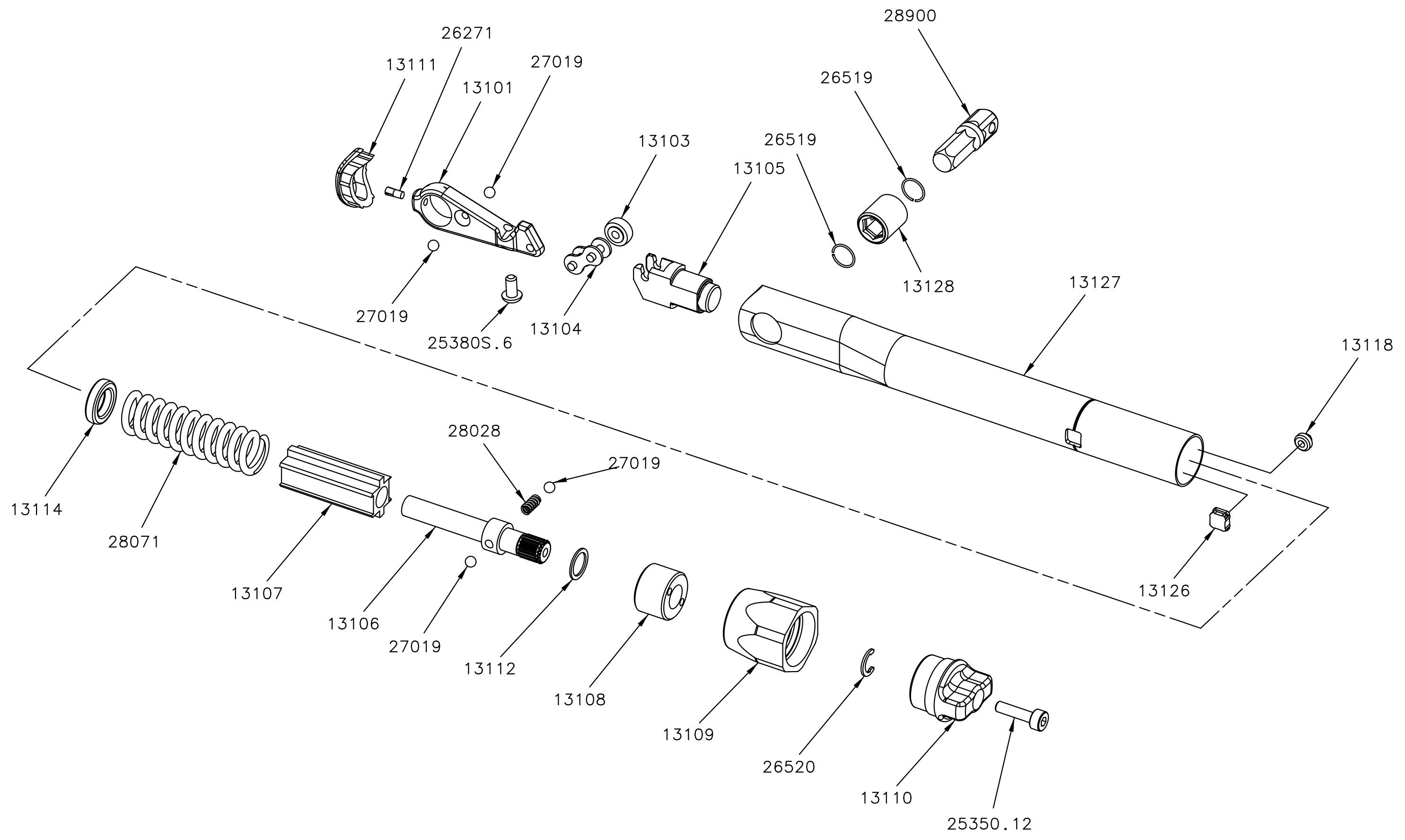

13001 - TW MDL5 ADJ 1-5 Nm

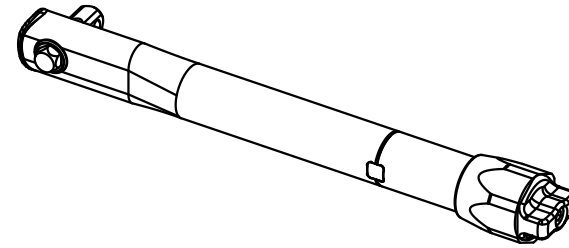

13101	1	PRIMARY LEVER
13103	1	GUIDE ROLLER
13104	1	CHAIN LINK 8mm OUTER LINK PAIR
13105	1	TRANSVERSE LINK
13106	1	ADJUSTING SCREW
13107	1	ADJUSTING NUT
13108	1	INDEX COLLAR
13109	1	LOCK NUT
13110	1	ADJUSTING KNOB
13111	1	END CAP
13112	1	WASHER THRUST
13114	1	GUIDE RING
13118	1	ADJUSTING NUT RETAINER
13126	1	SCALE LENS
13127	1	BODY TUBE MDL 5 - SQ WINDOW
13128	1	DRIVE CENTRE MDL 5 THROUGH HEX
25350.12	1	M3 X 12 SCS
25380S.6	1	M3 X 6 BUT.HD STAINLESS TUFLOK
26271	1	PIN GROOVED 2mm DIAx5 LONG
26519	2	WIRE RING FOR 1/4 HEX CENTRE
26520	1	CRCLP 1/4 DIA EXT CRESENT TYPE AND. NO
27019	4	STEEL BALL 3 DIA
28028	1	SPRG/COMP 3DIAx6.35x0.5WD
28071	1	SPRG. COMP. 12.50DX42LGX2.03WD
28900	1	ADAPTOR 1/4HEX- 1/4SQ M/M -REF ATA315
Part No	Qty	Description