

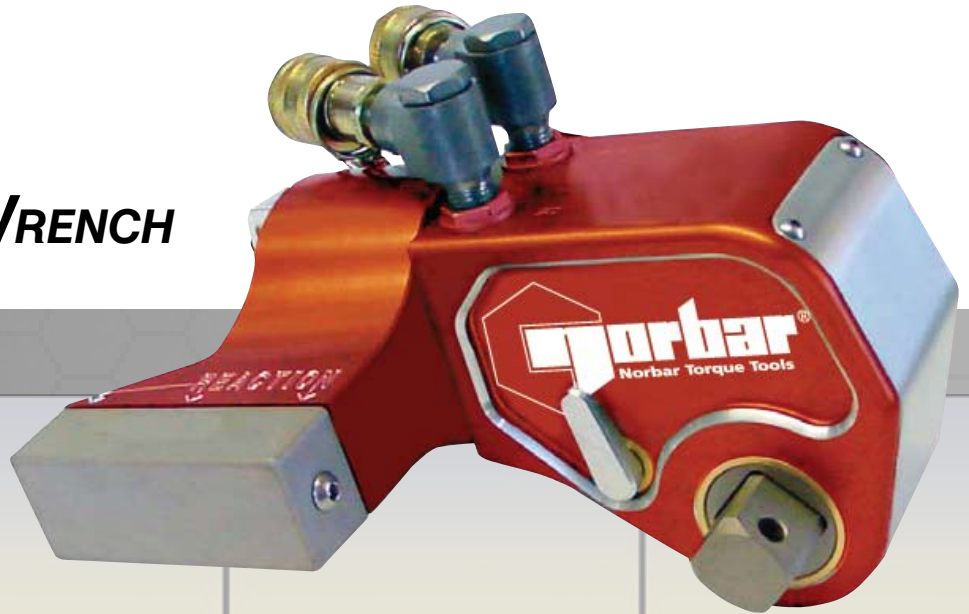

NSD SERIES
HYDRAULIC WRENCH



NHCL SERIES
HYDRAULIC WRENCH

NORBAR TORQUE TOOLS - HYDRAULIC WRENCHES



NSD Series

Norbar square drive hydraulic ratchet wrenches offer a cost efficient option to handle a wide range of bolt tightening and break-out needs. The NSD Series ratchet wrench employs a "patented design" which increases accuracy and reduces the number of moving parts. Our robust and lightweight aluminum body completely encloses the drive train assembly keeping the crucial lubricant inside the tool while significantly reducing the opportunity for outside elements to contaminate the inside of the tool.

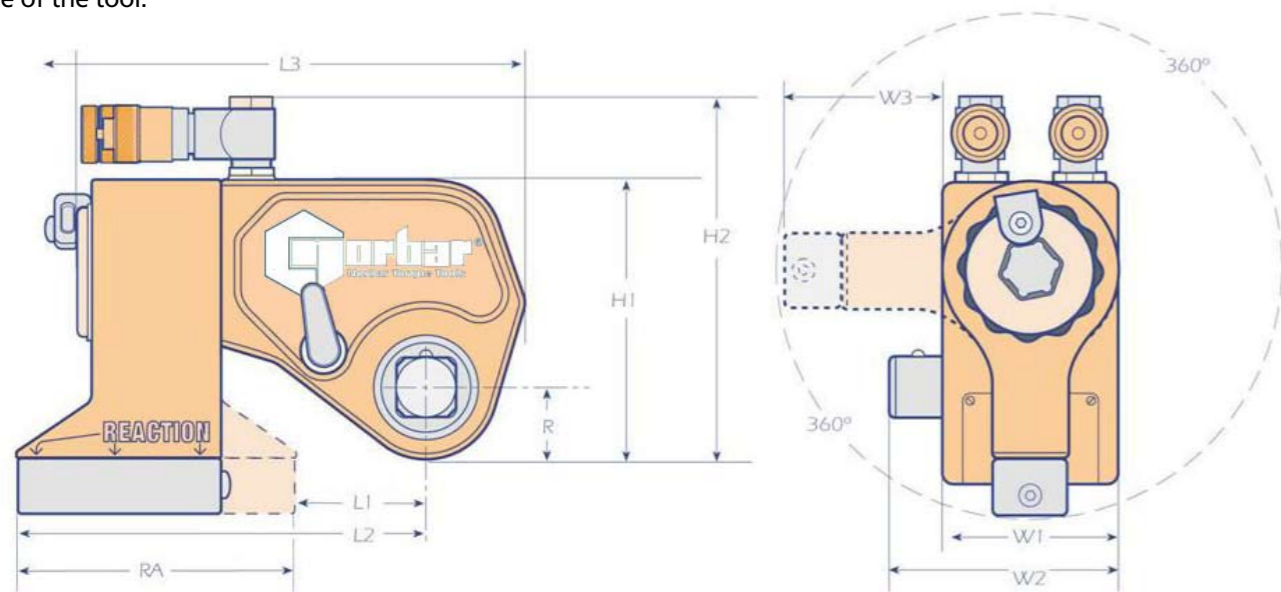

Square Drive - Tool Specifications

NHC/L Series

Norbar Inline hydraulic ratchet wrenches require minimum clearance while applying torque on the same plane as the nut, providing a marked improvement over square drive socket wrenches. Our patented design breakthrough reduces the overall dimensions of the inline ratcheting head allowing it to fit almost every application.

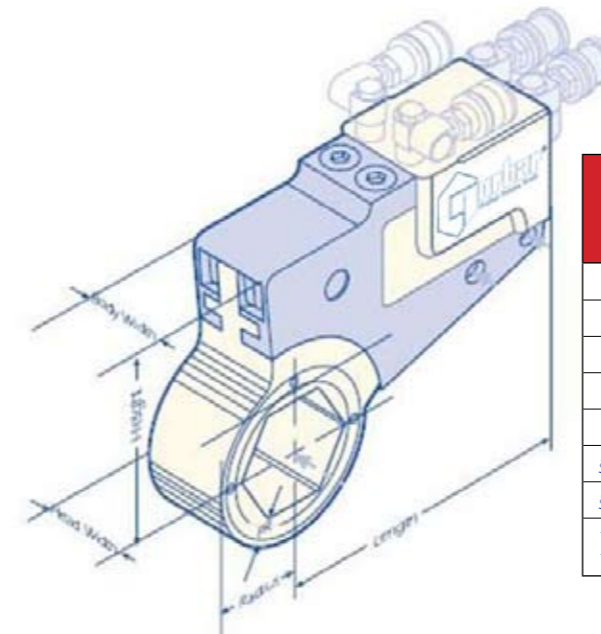

Hex Link - Tool Specifications

NHC Series	Min/Max, Ft.lbs. @ 700 bar (+/- 3%)	Length (inches)	Height (inches)	Body Width (inches)	Head Width (inches)	Range (inches)	Weight with Head (lbs.)
NHC-1800	117 / 1,294	6.250	4.000	1.100	0.950	3/4" - 2"	7.25
NHC-4500	294 / 3,074	7.000	5.750	1.450	1.075* or 1.200†	1-1/4" - 2-15/16"	9.25
NHC-9500	667 / 6,899	9.250	6.250	1.500	1.500	2" - 3-7/8"	14.00
NHC-14000	990 / 9,900	9.750	8.000	1.950	1.950	2-3/8" - 4-1/4"	24.50
NHC-23000	1,513 / 15,951	11.250	9.250	1.950	2.450	2-3/4" - 5-3/8"	42.00
§ NHC-35000	2,260 / 23,620	11.250	9.250	2.900	2.950	3-1/2" - 5-3/4"	57.00
§ NHC-65000	**	15.375	10.500	2.900	2.950	4-5/8" - 7-1/4"	85.00

* 1-1/4" to 2" Heads † 2-3/16" to 2-15/16" Heads §Steel Cylinders Only
** Please inquire for additional information.

NSD Series	Square Drive	Min/Max, Ft.lbs. @ 700 bar (+/- 3%)	Weight* (lbs.)	Reaction Area - RA	Length L1	Length L2	Length L3	Radius R	Height H1	Height H2	Width W1	Width W2	Width W3
NSD-1900	3/4"	143 / 1,382	5.25	3.685"	1.567"	5.252"	5.928"	1.200"	4.100"	5.725"	1.980"	2.730"	2.200"
NSD-4500	1"	262 / 2,921	11.25	5.335"	1.865"	7.200"	7.970"	1.260"	4.870"	6.520"	2.775"	3.600"	3.172"
NSD-8000	1-1/2"	564 / 5,110	17.20	5.460"	2.150"	7.610"	8.410"	1.725"	5.925"	7.850"	3.000"	4.475"	3.501"
NSD-15000	1-1/2"	1,038 / 10,793	29.90	6.500"	2.245"	8.745"	9.428"	2.062"	7.375"	9.125"	3.900"	5.350"	4.982"
NSD-27000	2-1/2"	1,753 / 17,934	62.00	7.525"	3.460"	10.375"	11.600"	3.000"	9.184"	10.784"	4.950"	7.450"	5.557"
NSD-40000	2-1/2"	2,638 / 25,804	75.00	7.525"	3.460"	10.875"	11.725"	3.125"	9.777"	11.377"	5.875"	8.375"	5.555"
NSD-60000†	2-1/2"	**	145.00	7.425"	7.337"	12.537"	13.312"	3.275"	11.225"	12.600"	5.750"	8.250"	5.500"
NSD-80000†	2-1/2"	**	295.00	8.781"	5.887"	14.668"	16.000"	3.750"	14.000"	15.600"	7.250"	9.750"	5.750"

*Weight includes tool, reaction member and square drive. †Steel Casting
**Please inquire for additional information.

NHL-1800 Heads (inches)			NHL-4500 Heads (inches)			NHL-9500 Heads (inches)			NHL-14000 Heads (inches)			NHL-23000 Heads (inches)			NHL-35000 Heads (inches)			NHL-65000 Heads (inches)		
AF	Radius	P/R	AF	Radius	P/R	AF	Radius	P/R	AF	Radius	P/R	AF	Radius	P/R	AF	Radius	P/R	AF	Radius	P/R
3/4"	1.07"	0.41"	1-1/4"	1.38"	0.35"	2"	1.80"	0.47"	2-3/8"	2.02"	0.45"	2-3/4"	2.50"	0.90"	3-1/2"	2.90"	0.87"	4-5/8"	3.92"	1.25"
1-1/16"	1.18"	0.34"	1-7/16"	1.46"	0.35"	2-3/16"	1.88"	0.47"	2-9/16"	2.15"	0.47"	2-15/16"	2.62"	0.90"	3-1/8"	3.18"	0.95"	5"	4.13"	1.25"
1-1/4"	1.29"	0.34"	1-5/8"	1.57"	0.35"	2-3/8"	2.02"	0.47"	2-3/4"	2.4"	0.55"	3-1/8"	2.70"	0.90"	4-1/4"	3.35"	0.90"	5-3/8"	4.35"	1.25"
1-7/16"	1.40"	0.34"	1-13/16"	1.70"	0.40"	2-9/16"	2.15"	0.47"	2-15/16"	2.55"	0.50"	3-1/2"	2.90"	0.90"	4-5/8"	3.58"	0.90"	5-3/4"	4.57"	1.25"
1-5/8"	1.51"	0.34"	1-7/8"	1.79"	0.46"	2-3/4"	2.40"	0.55"	3-1/8"	2.62"	0.55"	3-7/8"	3.18"	0.95"	5"	3.58"	0.96"	6-1/8"	4.78"	1.25"
1-13/16"	1.61"	0.34"	2"	1.79"	0.40"	2-15/16"	2.55"	0.50"	3-1/2"	2.85"	0.85"	4-1/4"	3.35"	0.96"	5-3/8"	4.10"	1.00"	6-1/2"	5.00"	1.25"
2"	1.72"	0.34"	2-3/16"	1.90"	0.40"	3-1/8"	2.62"	0.55"	3-7/8"	3.07"	0.85"	4-5/8"	3.58"	0.96"	5-3/4"	4.32"	1.02"	6-7/8"	5.22"	1.25"
			2-3/8"	1.97"	0.40"	3-1/2"	2.85"	0.63"	4-1/4"	3.26"	0.85"	5"	3.90"	1.00"				7-1/4"	5.43"	1.25"
			2-9/16"	2.12"	0.46"	3-7/8"	3.04"	0.60"				5-3/8"	4.10"	1.00"						
			2-3/4"	2.24"	0.46"															
			2-15/16"	2.36"	0.46"															

*Common AF sizes shown - other sizes available on request.



HEAD OFFICE - SOUTH AUSTRALIA
45-47 Raglan Avenue, Edwardstown SA, 5039 Australia
Tel: +61 (0)8 8292 9777 Fax: +61 (0)8 8292 9799
Email: norbar@norbar.com.au

NEW SOUTH WALES
Unit 33/72 - 80 Percival Road
Smithfield NSW 2164
Tel: +61 (0)2 9725 2831
Fax: +61 (0)2 9604 0951
Email: nsw@norbar.com.au

WESTERN AUSTRALIA
Unit 3/95 Bannister Road
Canning Vale WA 6155
Tel: +61 (0)8 9455 7717
Fax: +61 (0)8 9455 7979
Email: wa@norbar.com.au

VICTORIA
Unit 6/810 Princes Highway
Springvale VIC 3171
Tel: +61 (0)3 9562 3382
Fax: +61 (0)3 9562 3072
Email: vic@norbar.com.au

QUEENSLAND
Unit 5/55 Donaldson Road
Rocklea QLD 4106
Tel: +61 (0)7 3216 7600
Fax: +61 (0)7 3216 6392
Email: qld@norbar.com.au

NEW ZEALAND
65A O'Rorke Road
Penrose Auckland NZ
Tel: +64 (0)9 579 8653
Fax: +64 (0)9 579 8654
Email: nz@norbar.com.au

SOUTH EAST ASIA / SINGAPORE
60 Kaki Bukit Place
#09-16 Eunos Tech-Pack
Singapore 415979
Tel: +65 6841 1371
Fax: +65 6841 1372
Email: singapore@norbar.com.au

www.norbar.com

