



# MULTI CHANNEL LUBRO

## OPERATOR'S MANUAL (PART NUMBER 34371)

### Issue 1

Original instructions (ENGLISH)

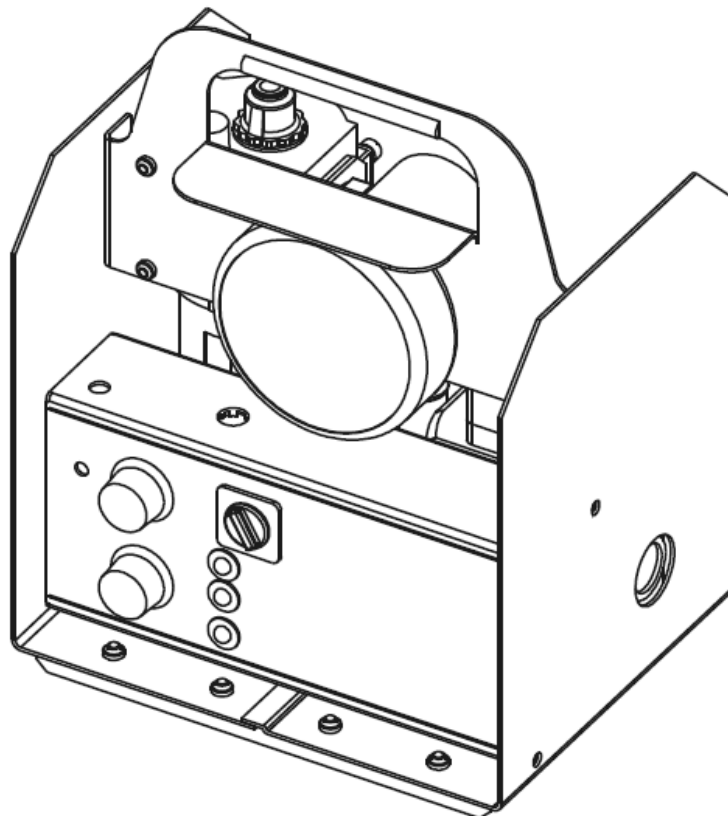

**PART NUMBERS COVERED BY THIS MANUAL**  
**MULTI CHANNEL LUBRO 60290**



## CONTENTS

	<u>PAGE</u>
<b>Safety</b>	<b>2</b>
<b>Introduction</b>	<b>3</b>
<b>Features and Functions</b>	<b>4</b>
<b>Set up Instructions</b>	<b>5</b>
<b>Operating Instructions</b>	<b>10</b>
<b>Maintenance</b>	<b>11</b>
<b>Specifications</b>	<b>13</b>
<b>Trouble shooting</b>	<b>14</b>

### Disposal



This symbol on the product indicates that it must not be disposed of in the general waste. Please dispose of according to your local recycling laws and regulations.

Contact your distributor or see the Norbar web site ([www.norbar.com](http://www.norbar.com)) for further recycling information.

## SAFETY

**IMPORTANT:**

**DO NOT OPERATE THE PRODUCT BEFORE READING THESE INSTRUCTIONS. FAILURE TO DO SO MAY RESULT IN PERSONAL INJURY OR DAMAGE TO THE PRODUCT.**

This product is intended for controlling the air pressure to Norbar Pneutorque® & similar pneumatic tools. Any other use is not recommended.

Read pneumatic tool manual before use.

It is recommended to have an air isolating device located in the air supply close to this product.

Isolate the tool from all energy sources before changing or adjusting the drive square or socket.

This product is designed for operation with compressed air. Compressed air can be dangerous for those unfamiliar with it. Only trained and experienced personnel should setup, operate and maintain pneumatically operated equipment.

Only connect to a clean dry air supply.

To avoid hazard from whipping air hoses make all connections before turning on the air supply.

Ensure any connected tool is 'OFF' before turning on air supply to prevent potential movement.

Not following correct maintenance procedures could cause the product to malfunction and could lead to damage to the equipment.

Before filling or maintaining this product, all compressed air should be exhausted.

If equipment is to be removed, first switch off air and electrical supplies and exhaust all residual compressed air in the system.

Do not make any modifications to the product.

Do not take the product apart, except where specified in the Maintenance section.







Keep this manual available for whenever necessary.

Only use supplied battery charger.

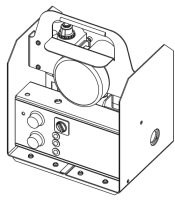

## INTRODUCTION

The Norbar Multi Channel Lubro (MCL) allows the user of pneumatic stall tools to instantly change between different air pressure settings. Up to 15 output air pressures can be set to suit up to 15 different applied torques.

**PARTS INCLUDED:-** \_\_\_\_\_

DESCRIPTION	MCL	Hose 3m	1/2" BSP M/M Adaptor	Battery Charger	Power cord	Key	Manual
PICTURE							
PART NUMBER	60290	28911	28604	39587	Various	39558	34371
QUANTITY	1	1	2	1	1	2	1

**ACCESSORIES:-** \_\_\_\_\_

DESCRIPTION	Hose 6m	Pressure Gauge	1/2" BSP Taper Thread Adaptor
PICTURE			
PART NUMBER	28912	28913	28918

## FEATURES AND FUNCTIONS

### INSTANT OPERATOR SETTING

15 different pressure settings can be stored that directly correspond to 15 different torque values to allow instant operator setting of pneumatic tools.

### METAL CARRY CRATE

Housed in a robust metal crate.

### KEY CONTROLLED SETUP

Unit can only be programmed via use of removable key, thus eliminating the possibility of inadvertent programming through operator error.

### REMOTE WORKING

Internal rechargeable battery pack to allow remote working for 16 hours. Electronic battery monitoring to show state of charge and prevent operation when battery voltage is low.

### AIR LUBRICATION

Ability to supply controlled oil feed for lubrication of connected tool.

### LARGE PRESSURE RANGE

Input pressure up to 145 psi / 10 bar.  
Output pressure from 7.25 psi / 0.5 bar to 95 psi / 6.5 bar.

### REUSEABLE LABEL

Front write-on label to store set pressure against job / torque value for each setting.

## SET UP INSTRUCTIONS

### PREPARATION:-

---

*If the equipment is used in a manner not specified by the manufacturer, the protection provided by the equipment may be impaired.*



**WARNING: TO AVOID HAZARD FROM WHIPPING AIR HOSES MAKE ALL CONNECTIONS BEFORE TURNING ON THE AIR SUPPLY.**

### Recommended installation considerations:

- Follow any applicable regulations and standards, e.g.:  
*“ISO 4414:1998 Pneumatic fluid power – General rules relating to systems”*
- Install near an air isolation valve.
- Keep enough space around the unit for safe operation & maintenance.
- Install vertically to allow all features to operate as intended.
- Do not use in a place subject to heavy vibrations and/or shocks.
- Use flexible hoses to reduce any load or vibration being passed to the unit.
- Keep hose length & number of fittings / connectors to a minimum.
- Handle with care to avoid damage to the precision components.
- Do not expose the product to direct sunlight for an extended period of time.
- Do not mount the product in locations where it is exposed to radiant heat.
- Ensure installation area is within specified temperature limits.
- Where a reduction in water vapour content is required, an air dryer should be considered.
- Ensure inlet mains air pressure does not exceed 145 psi / 10 bar / 1.0 MPa.
- Fill lubricator bowl before installation (see Maintenance section).

**OIL FOR AIR LUBRICATION:-** \_\_\_\_\_

If the connected pneumatic tool requires air lubrication, ensure the oil bowl contains oil. To check oil level and fill oil lubricator see Maintenance section.

**CHARGE BATTERY:-** \_\_\_\_\_

**NOTE: Use only battery charger provided (Norbar part 38587).**



**FIGURE 1 - Battery charger**

Connect power cord to battery charger.

**TIP:** If the power cord is to be changed ensure the new power cord socket end has an IEC60320 Standard Sheet C7 (figure of 8 style) connector to suit the battery charger.

If the power cord plug is re-wired consult a qualified electrician.

Connect battery charger to connector marked  on MCL.

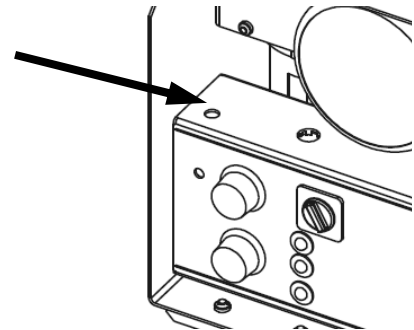

**FIGURE 2 - Charger input**

The LED on the battery charger will light up to show it is powered. To fully charge the battery can take up to 4 hours during which time the colour of the LED will change to indicate the charge status; see reverse of battery charger for details.

The MCL can be operated whilst being charged.

A fully charged battery will provide 16 hours of use.

**CONNECT AIR SUPPLY:-** \_\_\_\_\_

**WARNING:** TO AVOID HAZARD FROM WHIPPING AIR HOSES MAKE ALL CONNECTIONS TO THE TOOL BEFORE TURNING ON THE AIR SUPPLY.

Ensure all hoses are clean and free from any foreign material.

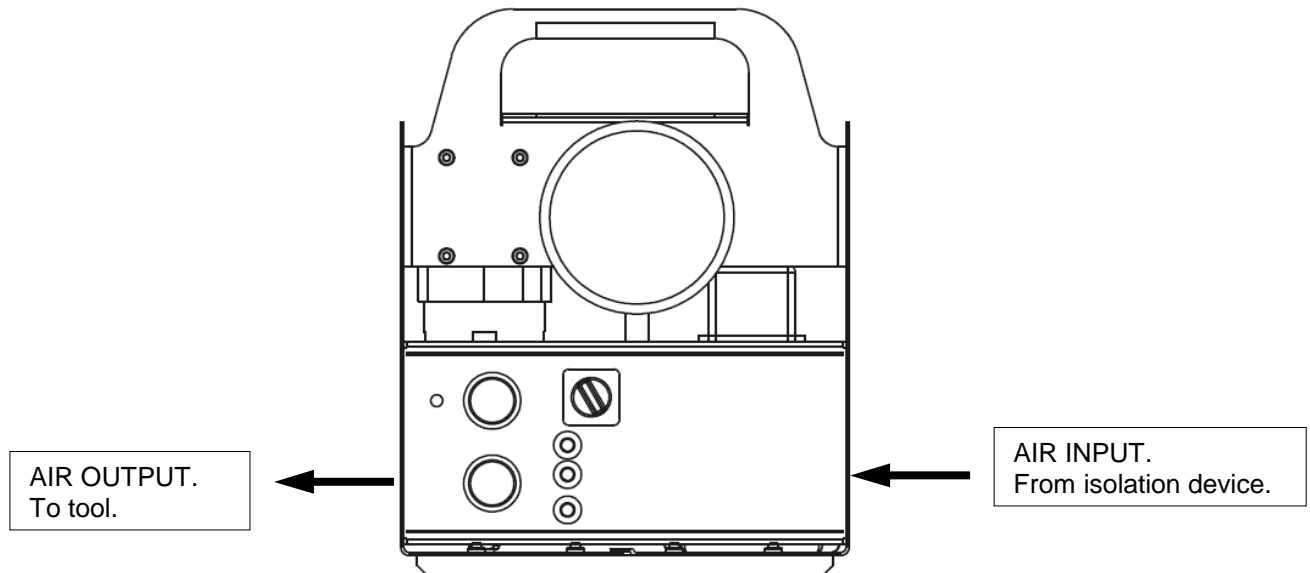

**FIGURE 3 - Air connections**

**TIP:** When using thread sealing tape start 1.5 to 2 threads from the end of the thread to ensure any potential loose tape cannot enter the air supply.

1. Connect air supply from isolation device to AIR INPUT using 1/2" female thread on RIGHT of MCL. Use a minimum hose size of 1/2" (12mm) bore. If required use 1/2" BSP m/m adaptor supplied. Tighten to 28-30 N·m. Do not over tighten as threads have a taper fitting.
2. Connect tool to AIR OUTPUT using 1/2" female thread on LEFT of MCL. If required use 1/2" BSP m/m adaptor supplied. Tighten to 28-30 N·m. Do not over tighten as threads have a taper fitting.
3. Ensure any connected tool is 'OFF' to prevent potential movement.
4. Apply mains air supply.
5. Check for leaks.

**SET PRESSURE (JOBS):** \_\_\_\_\_

15 locations are available to store 15 pressure settings that correspond to 15 torque values (jobs).

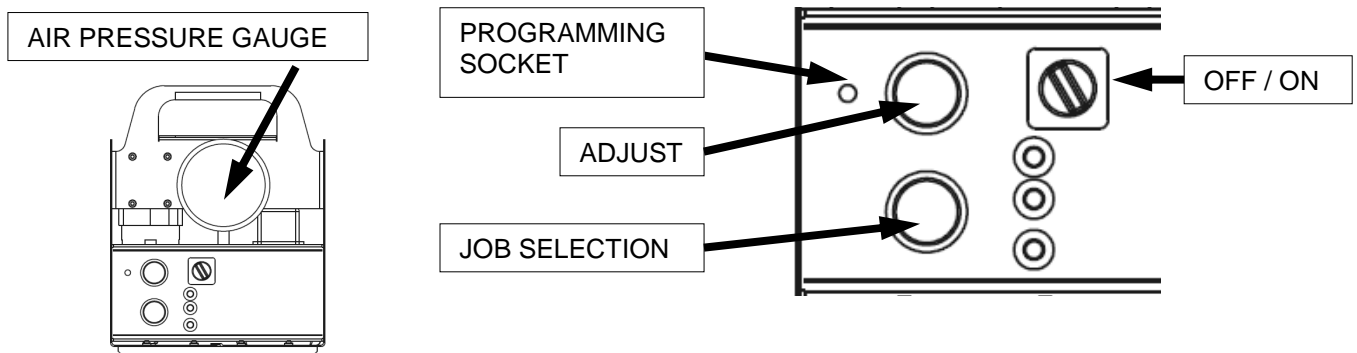

**FIGURE 4 - Controls**

1. Turn OFF.
2. Insert key into programming socket.
3. Turn ON. The green & red LEDs flash twice to confirm SET mode.
4. Turn JOB SELECTION switch to RESET.
5. Turn JOB SELECTION switch to required number.
6. Use air pressure graph (supplied with pneumatic tool) to find air pressure required for torque value. With the tool drive square free, run the tool.

**NOTE:** Initially the tool may not run; tool will run when an adjustment is made.

Turn ADJUST until correct pressure is shown on the air pressure gauge.

**TIP:** To allow for tool air consumption tool **MUST** run freely whilst adjustment is made.



**WARNING:** Do not exceed the maximum air pressure for the tool.  
Do not set the pressure above the maximum indicated on the pressure gauge.

7. Stop tool.
8. Remove key from programming socket.  
The green & red LEDs flash twice to confirm setting saved.

**NOTE:** Key **MUST** be removed for setting to be saved.

9. Complete write-on label by adding the pressure (psi / bar) and Job / torque value.

#	psi / bar	Job / N·m
1	3.5 psi	HUB
2	4.3 psi	WHEEL NUTS
3	5.1 psi	400 N·m
4		
5		
6		
7		
8		
9		
10		
11		
12		
13		
14		
15		

**FIGURE 5 - Example of front write-on label**

10. For the next setting repeat from step 1.
11. Turn off.
12. Store keys in separate location to prevent inadvertent programming through operator error.

**TIP:** Each JOB SELECTION (#) is pre-programmed at the factory.  
For unused jobs either program to zero pressure or mark label location "NOT IN USE".

**LUBRICATOR FLOW:** \_\_\_\_\_

Many air tools are designed to operate with a small amount of oil in the air flow; the MCL can supply this.

Refer to air tool manual for required flow rate.

With the tool drive square free, run the tool to draw air flow.

Count the number of oil drops per minute in the oil sight glass.

If adjustment is necessary insert 4mm (5/32") hex key (not provided) into top of sight glass.

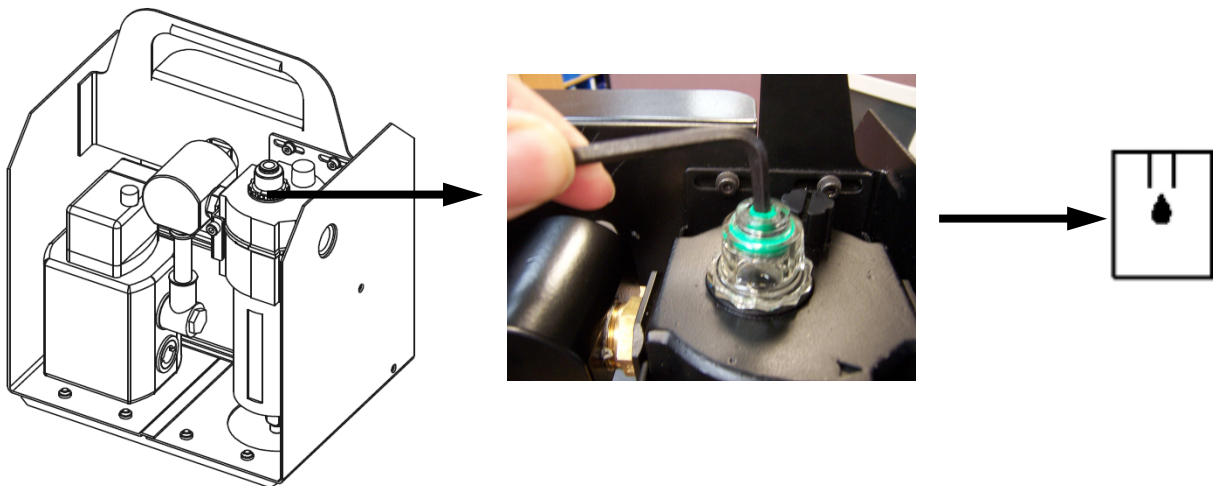

**FIGURE 6 - Lubricator flow adjustment**

Turn hex key clockwise  to decrease oil flow.

Turn hex key counter clockwise  to increase oil flow.

## OPERATING INSTRUCTIONS



**WARNING:** CHANGING THE INPUT MAINS AIR PRESSURE AFTER SETTING THE PRESSURES MAY CHANGE THE STALL TORQUE VALUE.

**BEFORE USE:** \_\_\_\_\_

Ensure the MCL has been connected and set up correctly (See SET UP INSTRUCTIONS).  
Ensure the inlet air pressure is present.



To operate from mains electrical power, connect battery charger to connector marked on MCL.

**DAILY CHECKS:** \_\_\_\_\_

Ensure lubricator bowl has sufficient oil (See MAINTENANCE).  
Ensure lubrication flow is correct (See SET UP INSTRUCTIONS).

If an external air filter is used, ensure filter bowl is not full or filter clogged.

**SELECT JOB:** \_\_\_\_\_

1. Turn ON; YELLOW power LED will be on.

The GREEN or RED battery status LEDs will be on or flashing. See table below for explanation.

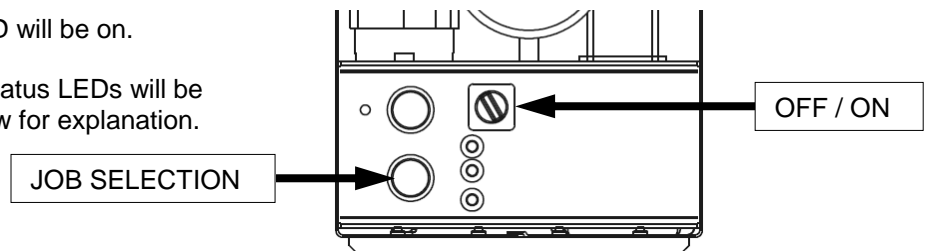

**FIGURE 7 - Controls**

	LED status	Battery status	Comment
<b>GREEN</b>	ON	OK	Up to 16 hours left.
	FLASHING	LOW	Battery low.
<b>RED</b>	ON	VERY LOW	Recharge battery.
	FLASHING	TOO LOW	Stop use and recharge battery. MCL is about to shut off.

2. Turn JOB SELECTION switch to RESET.  
**NOTE: This must be done to activate the MCL.**
3. Turn JOB SELECTION switch to required NUMBER (#).  
Operate pneumatic tool.
4. For next job turn JOB SELECTION switch to required NUMBER (#).  
Operate pneumatic tool.
5. Turn off.

#	psi / bar	Job / N·m
1	3.5 psi	HUB
2	4.3 psi	WHEEL NUTS
3	5.1 psi	400 N·m
4		
5		
6		
7		
8		
9		
10		
11		
12		
13		
14		
15		

**FIGURE 8 - Example of front label**

## MAINTENANCE

**WARNING:** \_\_\_\_\_



**NOTE:** *Always complete maintenance tasks in a clean work area.  
Always wear suitable gloves and eye protection.*



**WARNING: COMPRESSED AIR CAN BE DANGEROUS. SETUP, MAINTENANCE AND REPAIR OF PNEUMATIC SYSTEMS MUST BE PERFORMED BY QUALIFIED PERSONNEL ONLY. BEFORE CARRYING OUT MAINTENANCE ENSURE ALL AIR IS EXHAUSTED AND ALL ELECTRICAL POWER IS OFF.**

**GENERAL:-** \_\_\_\_\_

To maintain optimum performance and safety, regular maintenance needs to be carried out. This section details the user maintenance required; other maintenance or repairs should only be carried out by Norbar or a Norbar approved agent. Service intervals will depend on the type of usage and the environment in which the MCL is used.

Perform periodic checks for lubricator bowl level and check on the general condition of all hoses and features looking for cracks & leaks. Replace / fix any faults found.

**LUBRICATOR FILLING:-** \_\_\_\_\_

The MCL is fitted with an air lubrication device for pneumatic tools that require air lubrication.

If lubrication is used ensure the oil level is regularly checked.

The lubricator bowl is located at the rear of the MCL.

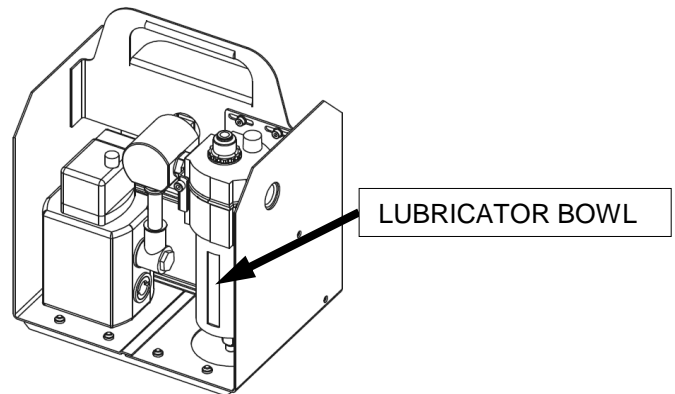

**FIGURE 9 - Lubricator bowl**

To fill the lubricator bowl:

Step	Procedure
1. Exhaust all air.	See WARNING at start of section. Read warning on the lubricator bowl.
2. Remove bowl.	Lift lubricator bowl, rotate counter clockwise 45° then pull bowl out. Replace bowl if damaged.
3. Fill.	Fill to " <b>MAX FILL</b> " level with oil. See specification for recommended oil.
4. Replace bowl.	Replace lubricator bowl and rotate clockwise 45° until the bowl locks in place.

**PRESSURE GAUGE:-** \_\_\_\_\_

The gauge is a precision item that must be treated with care. If the gauge is damaged replace as follows:

Step	Procedure
1. Exhaust all air.	See WARNING at start of section.
2. Remove gauge.	Use 16mm spanner to hold nut at back of the gauge. Rotate gauge counter-clockwise to remove.
3. Prepare new gauge.	When using thread sealing tape start 1.5 to 2 threads from the end of the thread to ensure any potential loose tape cannot enter the air supply.
4. Replace gauge.	Use 16mm spanner to hold nut at back of the gauge. Rotate gauge clockwise to mount. Tighten to 12 – 14 N·m.
5. Apply operating pressure.	Check for proper operation and possible air leaks.

**CLEANING:-** \_\_\_\_\_

Keep the MCL in a clean condition to aid safety. Do not use abrasives or solvent based cleaners.

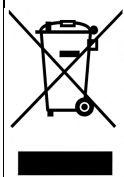
**DISPOSAL:-** \_\_\_\_\_

This symbol on the product indicates that it must not be disposed of in the general waste. Please dispose of according to your local recycling laws and regulations.

Contact your distributor or see the Norbar web site ([www.norbar.com](http://www.norbar.com)) for further recycling information.

## SPECIFICATIONS

### AIR:-

---

Input air quality	Dry filtered air supply, 5µm filtration.
Input / output port thread	1/2" BSP (British Standard Pipe).
Minimum hose bore	1/2" (12mm).
Input pressure	Maximum 145 psi / 10 bar / 1.0 MPa.
Output pressure	Minimum 7.25 psi / 0.5 bar.
	Maximum 95 psi / 6.5 bar.
Pressure gauge range	0 to 100 psi / 6.9 bar.

### OIL:-

---

Recommended:	Shell Tellus 15 or BP ENERGOL HLP 32 or equivalent.
--------------	---

### ELECTRICAL:-

---

Battery charger input	100 to 240 V a.c. at 50-60 Hz.
Electrical power consumption	16 W - maximum.
Battery	1.6 Ah, 24 volt NiMH (Nickel metal Hydride).
Battery charge time	Up to 4 hours (see LED on charger for battery status).
Battery life	16 hours nominal.
Charger Input protection	Non-replaceable fuse.
Charger output protection	Polyswitch fuse.

### MECHANICAL:-

---

Dimensions	288 mm high x 226 mm wide x 180 mm deep.
Weight	MCL 5.5 Kg.
	Hose 3m 1.5 Kg.

### ENVIRONMENTAL:-

---

Location	Indoor use.
Temperature Range:	Mains use 0°C to +40°C.
	Battery use 0°C to +50°C.
	Storage -20°C to +60°C.
Altitude	Up to 2000m.
Maximum Operating Humidity:	Maximum relative humidity 80% for temperatures up to 31°C decreasing linearly to 50% relative humidity at 40°C.
IP code	40.
Transient overvoltage	Up to Overvoltage Category II.
Pollution Degree	2.

### CONFORMITY:-

---

Electromagnetic Compatibility (EMC) Directive	In conformance with EN 61326:2006.
Low voltage directive	In conformance with EN 61010-1:2010.

*Due to continuous improvement all specifications are subject to change without prior notice.*

## TROUBLE SHOOTING

Tips are located within the manual to help with troubleshooting.

Common problems are listed below, for more complex faults please contact your local Norbar distributor or Norbar directly.

PROBLEM	LIKELY SOLUTIONS
MCL does not turn on.	Battery needs charging. Attach battery charger.
Battery will not charge.	Check LED on battery charger; colour of LED will indicate the charge state, see reverse of battery charger for details.  If battery charger LED off, check a.c. power.
MCL operates on battery for a short time.	Ensure battery has been fully charged for at least 4 hours. Else internal battery pack needs replacing. Return to Norbar.
Attached tool will not operate.	Check air supply is functioning & connected. Check output air pressure setting (at least 15 psi / 1 bar required for most tools).
Output pressure too low.	Ensure input air pressure is approximately 15 psi / 1 bar above required output pressure, due to losses in MCL.
Pressure not regulated.	Check orientation of AIR INPUT & TOOL OUTPUT connections.
Air leak.	Investigate area of leak.  Check for loose part, crack or break of component or foreign matter in system.  Always tighten components to correct torque value.
Air flow reduced.	External filter element is clogged; replace external element.
Fluid in outlet hose.	External filter bowl is full; drain external filter bowl.
Oil does not drop.	Ensure amount of oil in lubricator bowl is sufficient. Ensure air flow is sufficient to allow oil flow. Increase oil flow (see page 9). Ensure there are no air leaks from the lubricator bowl.