

Non - Magnetic 1-20 N.m

Non - Magnetic 8-50 N.m

Non - Magnetic 1-20 N.m, Non - Magnetic 8-50 N.m

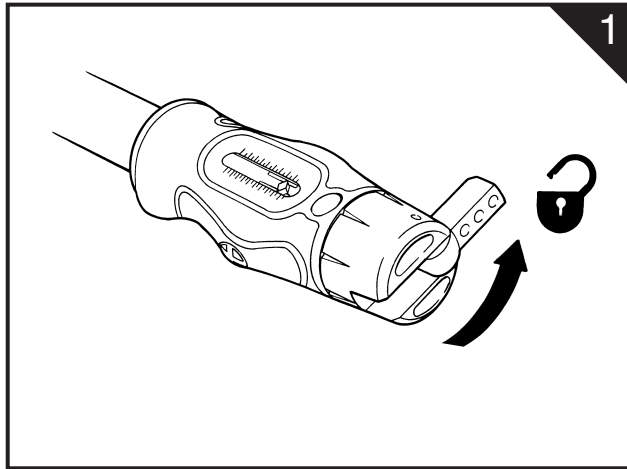

1

- Unlock • Déverrouiller la mollette
- Entichern • Sbloccare • Desbloquear

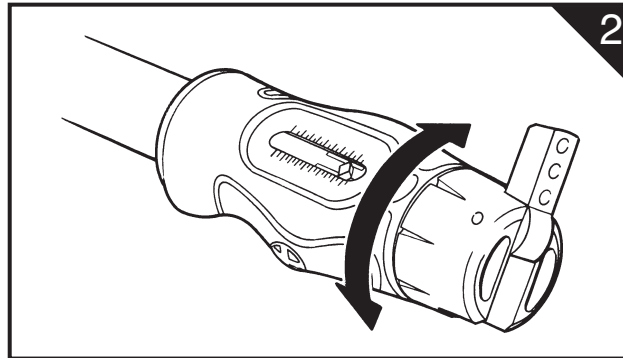

2

- Turn knob to adjust • Tournez le pommeau pour régler
- Zur Einstellung des gewünschten Wertes, betätigen Sie den Drehknopf am Ende des Handgriffes
- Ruotare il pomello di regolazione
- Ajuste el par girando extremo

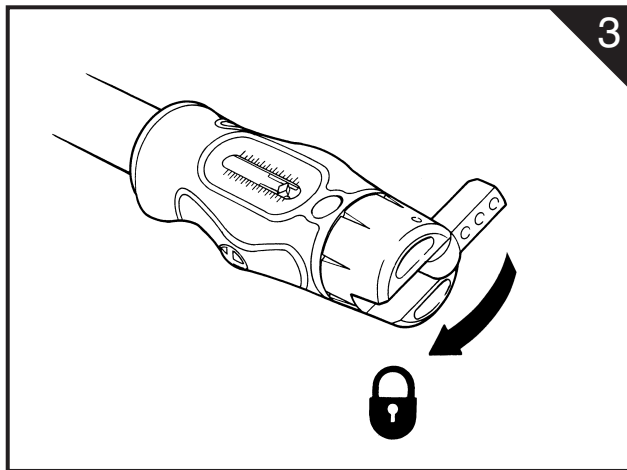

3

- Lock • Verrouiller la mollette
- Sichern • Bloccare • Bloquear

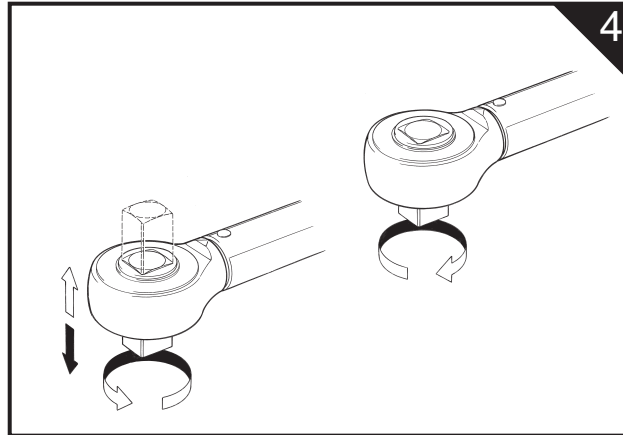

4

- Set ratchet direction • Régler la direction de serrage
- Wahl der Arbeitsrichtung • Fissare direzione cricchetto
- Seleccionar

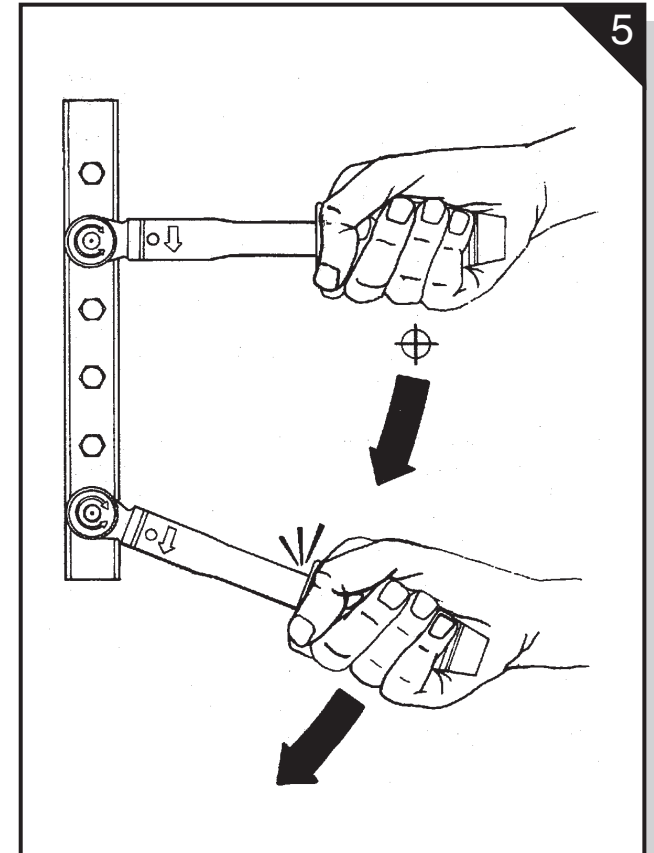

5

- Pull smoothly from the marked 'Load Point'
- Tirer doucement à partir du 'Load Point' repéré
- Langsam ab dem markierten 'Load Point' drehen
- Tirare dolcemente dal 'Load Point' Indicato
- Accione lentamente en el lugar indicado 'Load point'