

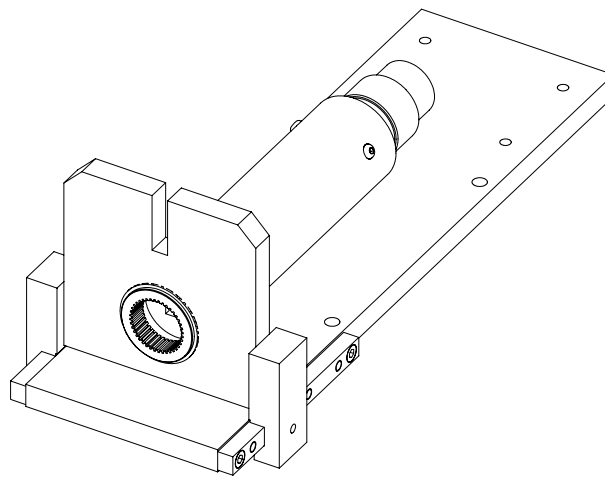

# Power Tool Test Fixture For TruCheck Plus 1000

**OPERATOR'S HANDBOOK (PART No 34344) Issue 1**  
(ENGLISH)



**This handbook covers part numbers:**

**50757 – Power Tool Test Fixture for TruCheck Plus 1000**  
**50758 – 1000 N.m Joint Simulator Rundown Assembly**







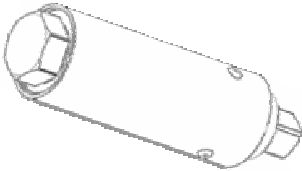
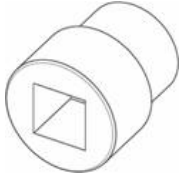

## INTRODUCTION

The power tool test fixture acts as a repeatable bolted joint to enable the consistency of non-impact power torque tools to be measured. This handbook covers a Norbar Power Tool Test Fixture (50757) and Joint Simulator Rundown Assembly (50758) that has been designed to be used in conjunction with a Norbar TruCheck Plus 1000 (43231) and the following range of Pneutorque wrenches:

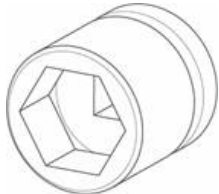
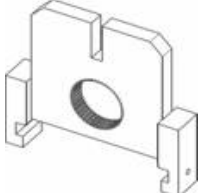
- PTM-52 series
- PT 72 series
- PTM-72 series
- PTME-72 series

The joint simulator uses disc-springs to control the joint rate. The springs are designed to cope with repetitive testing at rated capacity, so the performance remains consistent over the product life.

PART NUMBER / DESCRIPTION	DRAWING	PART NUMBER / DESCRIPTION	DRAWING
50758 - JOINT SIMULATOR **		29403 - 27 A/F - 1" DRIVE SOCKET	
62232/62234 - BASE PLATE/SIDE RUNNERS		29323 - 46 A/F - 3/4" DRIVE SOCKET	
62235 - REACTION PLATE		29413 - 46 A/F - 1" DRIVE SOCKET	
62236 - REACTION PLATE ADAPTOR		29351 - 1" MALE - 3/4" FEMALE ADAPTOR	
26486 - CIRCLIP RETAINING RING			

\*\* Item can be supplied separately for customers who wish to use their own reaction design.

## FEATURES AND FUNCTIONS

- ▶ A consistent joint for power tool testing.
- ▶ Directly compatible with Norbar PT's (specified above) and Norbar TruCheck Plus 1000.
- ▶ For clockwise testing of power tools.

## SET UP

*If the equipment is used in a manner not specified by the manufacturer, the protection provided by the equipment may be impaired.*

### 1. BASE:- \_\_\_\_\_

Secure fixture base (62232) to a suitable surface using 4 x M10 socket head cap screws (minimum grade 8.8).

Ensure there is sufficient overhang to slide reaction plate onto base.

Torque tighten screws to a value of 45-50N.m (33-37 lbf.ft).

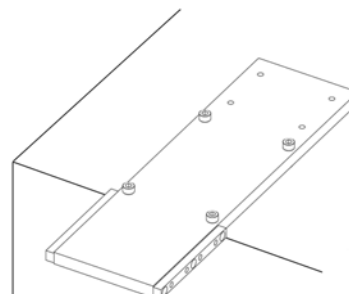

### 2. TRUCHECK:- \_\_\_\_\_

Mount the TruCheck Plus onto the base plate.

Set-up the instrument as specified in the TruCheck handbook.

Ensure TruCheck Plus is in "dIAL" mode.

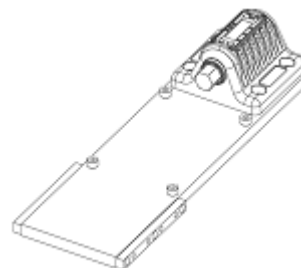

### 3. POWER TOOL TEST FIXTURE:- \_\_\_\_\_

Position the joint simulator (50758) onto the TruCheck Plus instrument using the adaptor supplied (29403).

Slide reaction plate (62235) onto bed. If required, fit the splined reaction adaptor (62236) to reaction plate (for 52mm tools).

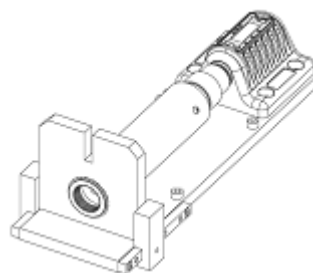

### 4. TOOL:- \_\_\_\_\_

Connect up power tool as detailed in power tool handbook. **DO NOT USE IMPACT TOOLS.**

Ensure torque setting on power tool is not above maximum rating for transducer.

Ensure torque setting on power tool is not above maximum rating for joint simulator.

Engage tool with reaction plate, either via splined location or blade reaction location. Secure in place using retaining ring.

Fit required adapter(s) to fix power tool to joint simulator and reaction.

## OPERATING INSTRUCTIONS

Note: *Exceeding maximum torque for washer make-up will result in permanent damage to washers.  
Keep bolt and washers greased with graphite loaded grease. See Maintenance section.*

### 1. TIGHTENING:- \_\_\_\_\_

Run tool in to joint simulator in CLOCKWISE direction.

Read torque value from measurement instrument.

### 2. RELEASING:- \_\_\_\_\_

To release joint simulator rotate the hexagon bolt in an ANTI-CLOCKWISE direction.

Reset measurement instrument as required.

## SPECIFICATIONS

Part Number	50758	50757
Capacity	1000 N.m (738 lbf.ft)	1000 N.m (738 lbf.ft)
Overall Dimensions (Approx.)	240mm x Ø70mm	210 x 190 x 550
Weight	5.5 Kg	16.5 Kg
Hexagon Bolt A/F	46mm	
Interface to transducer	27mm A/F to 1" Sq.	

Operating temperature range: 0°C to +50°C.

Storage temperature range: -20°C to +70°C.

Maximum operating humidity: 85% Relative Humidity @30°C.

Environment: Indoor use within a light industrial environment.

*Due to continuous improvement all specifications are subject to change without prior notice.*

## MAINTENANCE

NOTE: *Always complete maintenance tasks on a clean work area.  
Always wear suitable gloves for your protection.*

### SERVICE / REPAIR:- \_\_\_\_\_

To service or repair the joint simulator, complete the following steps:

1. Remove joint simulator from TruCheck Plus.
2. Unscrew M30 hexagon bolt (25574) in an anti-clockwise direction.

The M30 hexagon bolt is the item most prone to wear. It is recommended to grease this item regularly with Rocol M204 G Graphite grease or Rocol Tufgear 85. Replace hexagon bolt when worn.

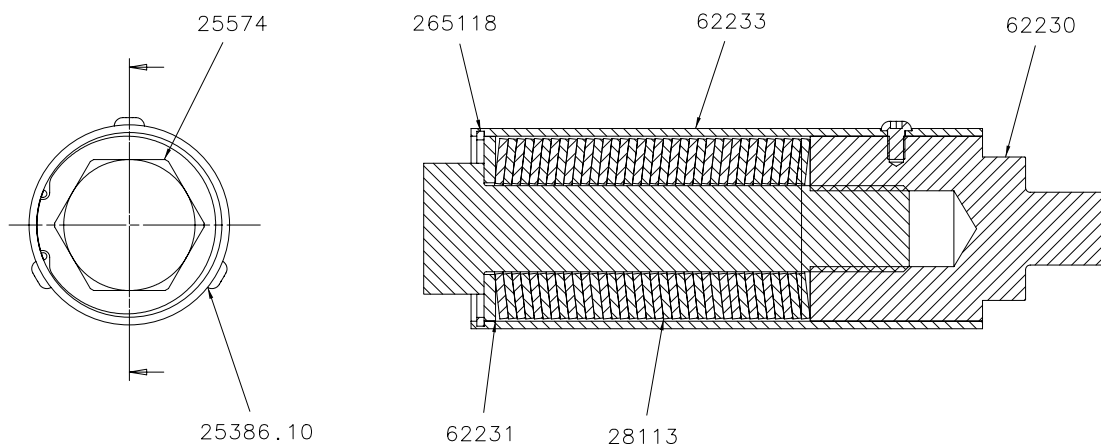

3. To access the spring(s):  
Remove the 3 x M5 button head screws that retain the drive shaft (62230).  
Slide out the drive shaft to reveal the disc-spring stack.  
  
It is important to note the orientation of the spring(s) ready for reassembly.
4. Clean spring(s) or replace with new spring(s).  
Grease springs with Rocol M204 G Graphite grease or Rocol Tufgear 85.
5. Replace disc-spring stack paying careful attention to arrangement.
6. Replace drive shaft and retain with 3 x M5 button head screws.
7. Grease and replace M30 hexagon bolt.

### CLEANING:- \_\_\_\_\_

Do not use abrasives or solvent based cleaners.

### DISPOSAL (RECYCLING CONSIDERATIONS):- \_\_\_\_\_

Component	Material
Joint Simulator Housing	Steel
M30 Hexagon Bolt	Steel
Base Plate/Side Runners	Aluminium/Steel
Reaction Plate	Steel
Reaction Adaptor	Steel
Hardened Washer	Steel

For up to date disposal information, see our web site [www.norbar.com](http://www.norbar.com).