

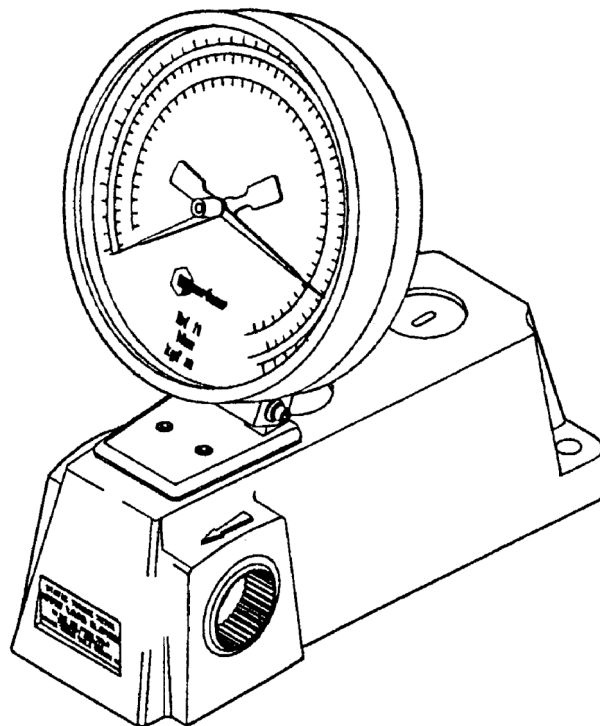

NORBAR STATIC TORQUE METER

OPERATORS HANDBOOK (PART NO. 34075.HP)



NORBAR TORQUE TOOLS LTD, Beaumont Road, Banbury, Oxfordshire, OX16 1XJ, UNITED KINGDOM
Tel : + 44 (0) 1295 270333, Fax : + 44 (0) 1295 753643

www.norbar.com

enquiry@norbar.com

CONTENTS

	<u>PAGE</u>
Part Numbers Covered by Handbook	1
Set Up Instructions	2
Operating Instructions	3
Testing Click and Slipping Type Torque Wrenches	3
Testing Dial and Bending Beam Torque Wrenches	3
Parts List	4

PART NUMBERS COVERED BY HANDBOOK

Part Number	Model	Range				
		N.m	lbf.ft	lbf.in	Kgf.m	Kgf.cm
21020.HP	60	2.5-60	2.5-46	-	-	25-625
21020.INS.HP	60.INS	2.5-60	-	30-550	-	25-625
21022.HP	250	10-250	10-184	-	1-25	-
21023.HP	500	25-500	20-370	-	2.5-50	-
21024.HP	1000	50-1000	40-750	-	5-100	-
21025.HP	2000	100-2000	80-1500	-	10-200	-
21026.HP	4000	200-4000	160-3000	-	20-400	-

This handbook covers Norbar Static Torque Meters with a 'HP' suffix to the part number. The 'HP' suffix denotes calibration has been completed in the HORIZONTAL PLANE.

"HP" is also marked on the face of the dial.

SET UP INSTRUCTIONS

The Norbar Static Torque Meter must be rigidly mounted on a horizontal surface using 1/2" (M12) bolts.

The device has been calibrated in the horizontal plane only in accordance with clause 3.5 of BS 7882:2008. In order to maintain the calibration accuracy the device should only be mounted in the horizontal plane and the gauge inclined as shown in the following diagram:

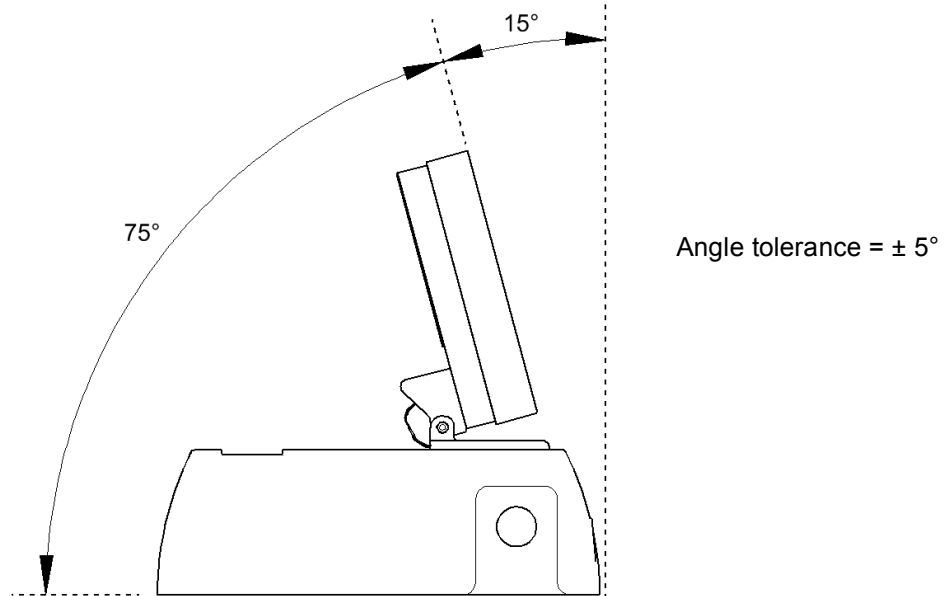

Any deviation from this may cause errors in excess of those reported on the calibration certificate.

Splined square drive adapters are supplied to accommodate different sizes of torque wrench square drives. These adaptors fit into the double ended meter drive spindle (left side for right handed operation and vice versa).

To maintain the specified accuracy it is recommended that Static Torque Meter is recalibrated at least once per year. Re-calibration and repair should be carried out at Norbar or by a Norbar approved agent.



Norbar Static Torque Meters are not suitable for testing impact power tools and serious damage will result if this is attempted.

OPERATING INSTRUCTIONS

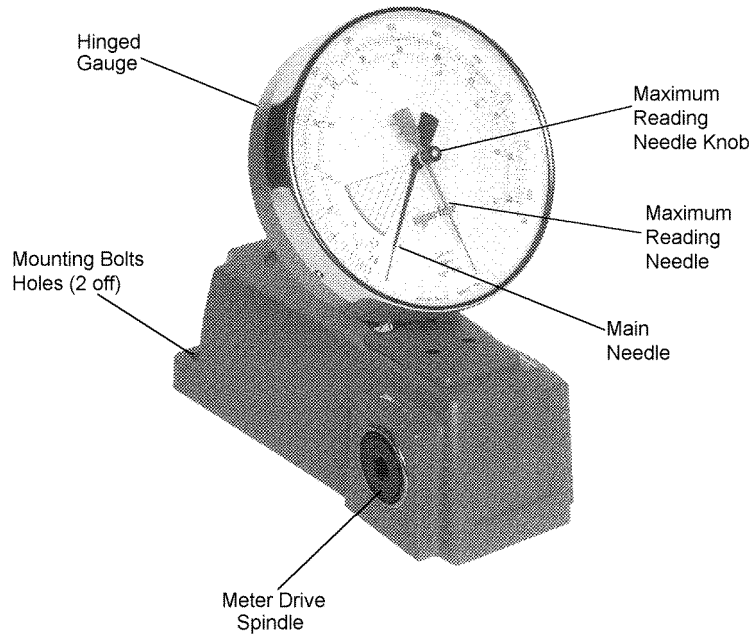

Select the appropriate splined adaptor to suit the square drive of the torque wrench to be tested. Insert this into the correct side of the meter drive spindle and fit the wrench into the adaptor ensuring that the wrench handle is approximately horizontal.

The gauge face must always be read at 90° to the operator's line of sight to prevent parallax error.

TESTING CLICK AND SLIPPING TYPE TORQUE WRENCHES _____

Using the knob in the centre of the dial face rotate the maximum reading needle fully clockwise.

Apply hand pressure perpendicularly to the centre of the torque wrench handle slowly and smoothly until the wrench clicks or slips and note the meter reading.

WARNING: THE MAXIMUM READING NEEDLE MUST NOT BE USED WHEN TESTING CLICK AND SLIPPING TYPE TORQUE WRENCHES.



Care must be taken to ensure that the meter is not overloaded as this will cause serious damage to the gauge mechanism.

TESTING DIAL AND BENDING BEAM TORQUE WRENCHES _____

Using the knob in the centre of the gauge face rotate the maximum reading needle anti-clockwise until it rests against the needle at the zero position.

When the figure has been noted the maximum reading needle can be returned to the zero for the next reading.



Care must be taken to ensure that the meter is not overloaded as this will cause serious damage to the gauge mechanism.

PARTS LIST

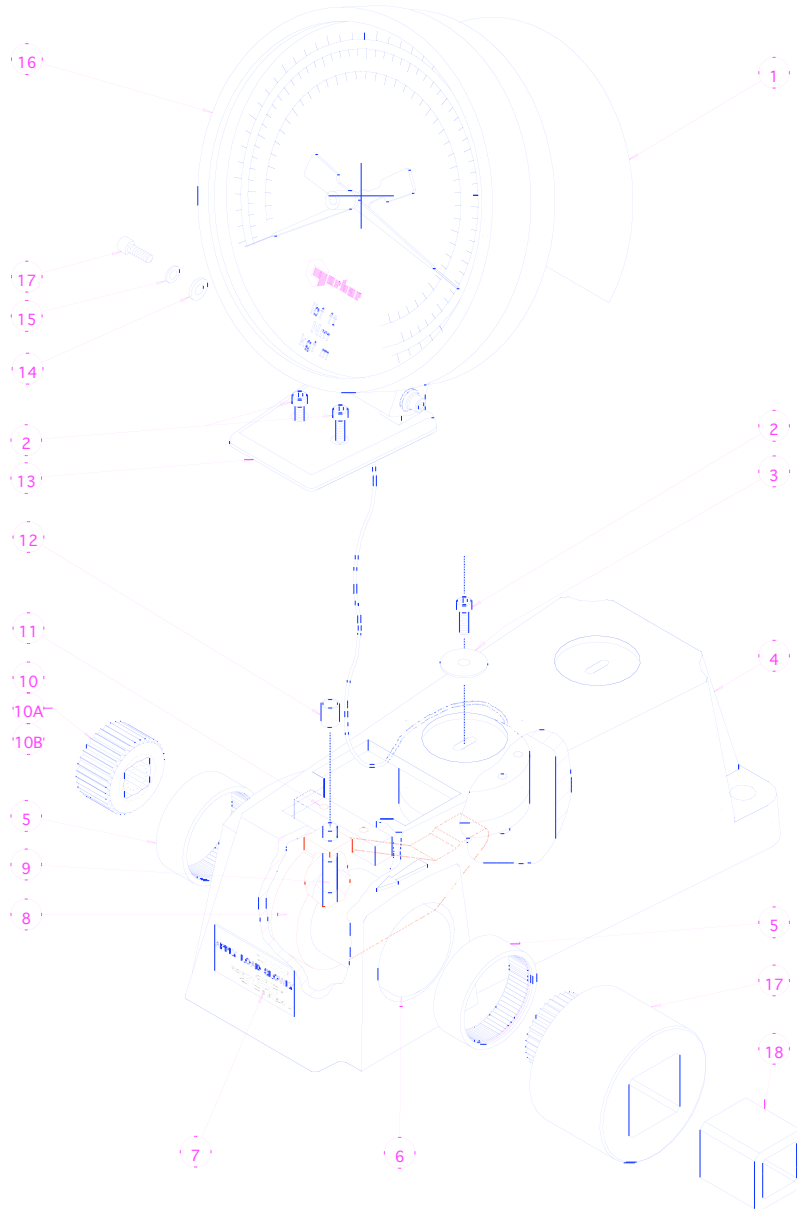

21020.HP – MODEL 60 (BASIC KIT)

<u>ITEM NO.</u>	<u>PART NO.</u>	<u>DESCRIPTION</u>	<u>QUANTITY</u>
1	Not Used		0
2	25352.16	M5 x 16mm LONG CAP SCREW	5
3	25909	1/4" ID x 1" OD WASHER	1
4	21200	HOUSING	1
5	27113	BEARING	2
6	21210	SPINDLE	1
7	10294.NOR	LABEL	1
8	21206	100mm LEVER ARM	1
9	26213	DOWEL PIN 8mm DIAx20mm LONG	2
10	21112	3/8" SQ. SERRATED ADAPTOR	1
10A	21113	1/2" SQ. SERRATED ADAPTOR	1
11	21202	CLAMPING BAR	1
12	27405	BEARING BUSH	1
13	21201	COVER PLATE	1
14	25908	1/4" ID x 1/2" OD WASHER	2
15	25953	M5 STANDARD WASHER - C FORM	2
16	27625	46 lbf.ft/625 kgf.cm GAUGE	1

Parts list changes from the basic kit for other models:

21020.INS.HP – MODEL 60 (IN VERSION)

<u>ITEM NO.</u>	<u>PART NO.</u>	<u>DESCRIPTION</u>	<u>QUANTITY</u>
16	27628	550 lbf.in/625 kgf.cm gauge	1

All other parts as basic kit (shown on previous page).

21022.HP – MODEL 250

<u>ITEM NO.</u>	<u>PART NO.</u>	<u>DESCRIPTION</u>	<u>QUANTITY</u>
10B	21114	3/4" SQ. SERRATION ADAPTOR	1
16	27621	184 lbf.ft 125 kgf.m GAUGE	1

All other parts as basic kit (shown on previous page).

21023.HP – MODEL 500

<u>ITEM NO.</u>	<u>PART NO.</u>	<u>DESCRIPTION</u>	<u>QUANTITY</u>
10	21114	3/4" SQ. SERRATION ADAPTOR	1
10B	21115	1" SQ. SERRATION ADAPTOR	1
16	27623	370 lbf.ft/50 kgf.m GAUGE	1

All other parts as basic kit (shown on previous page).

21024.HP – MODEL 1000

<u>ITEM NO.</u>	<u>PART NO.</u>	<u>DESCRIPTION</u>	<u>QUANTITY</u>
10	21114	3/4" SQ. SERRATION ADAPTOR	1
10B	21115	1" SQ. SERRATION ADAPTOR	1
16	27617	750 lbf.ft/100 kgf.cm GAUGE	1

All other parts as basic kit (shown on previous page).

21025.HP – MODEL 2000

<u>ITEM NO.</u>	<u>PART NO.</u>	<u>DESCRIPTION</u>	<u>QUANTITY</u>
10	21114	3/4" SQ. SERRATION ADAPTOR	1
10B	21115	1" SQ. SERRATION ADAPTOR	1
16	27619	1500 lbf.ft/200 kgf.cm GAUGE	1

All other parts as basic kit (shown on previous page)

21026.HP – MODEL 4000

<u>ITEM NO.</u>	<u>PART NO.</u>	<u>DESCRIPTION</u>	<u>QUANTITY</u>
8	21208	200mm LEVER ARM	1
10	21114	3/4" SQ. SERRATION ADAPTOR	1
16	27629	3000 lbf.ft/400 kgf.m GAUGE	1
17	21204	1 1/2" SQ. SERRATION ADAPTOR	1
18	21214	1 1/2" - 1" SQ. ADAPTOR	1

All other parts as basic kit (shown on previous page) - except for item 10A which is not supplied.