

Torque Reaction Principles of Torque Reaction

Newton's law dictates that for every applied force there is an equal and opposite reactive force. For applications requiring relatively low torques that can be applied with a torque wrench this does not present a problem as the reactive force is absorbed by the operator. However, if the desired torque necessitates the use of a multiplier, the resultant reactive force can only be absorbed using an appropriate reaction device.

For this reason all Norbar multipliers are supplied with a reaction plate or reaction foot fitted as standard.

All of the standard reaction plates and feet illustrated have been designed to enable the multiplier's use in a variety of environments but, due to an infinite number of bolting arrangements, it is impossible to have one reaction device that will satisfy every customer's requirement.

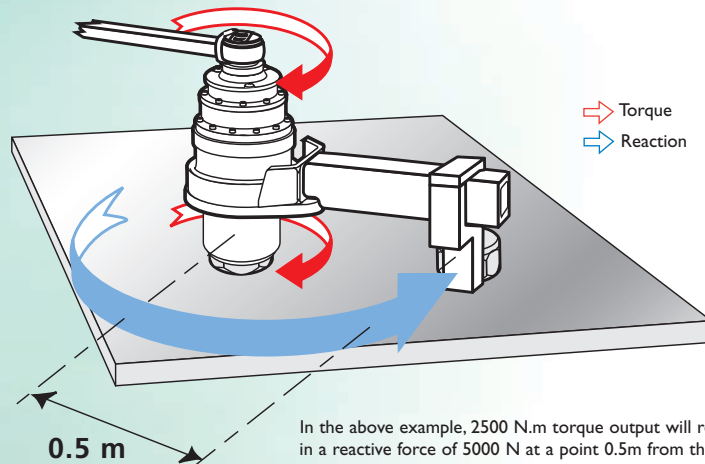

In the above example, 2500 N.m torque output will result in a reactive force of 5000 N at a point 0.5m from the axis of rotation or 2500 N at 1m (see page 63).

What to do if the standard reaction device is not suitable

For those applications that do not permit the use of a standard reaction plate the customer has three options.

- Norbar or an authorised Norbar distributor will design and manufacture a special purpose reaction plate to the customer's requirements.
- The customer can modify the standard reaction plate to suit his requirements.
- The customer can fabricate his own reaction device after liaison with Norbar's technical department or a Norbar distributor.

Customers wishing to either modify the original reaction plate or fabricate their own device should read the information on page 63 to avoid common torque reaction problems.

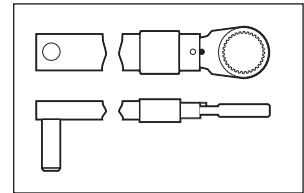

Optional on PTM-52 and PTM-72,
Standard on PT72mm Series

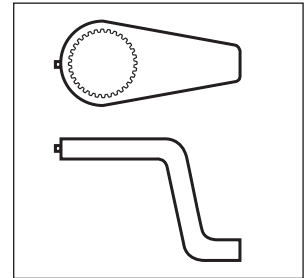

HT-52, HT-72, HT30/HT60,
PT2700/PT5500, PTM-52, PTM-72

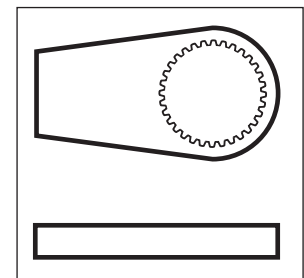

Optional Reaction Plate, 72mm
Series

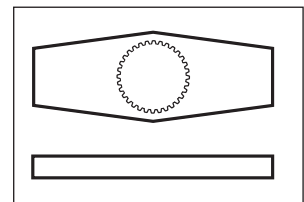

Optional Double Ended Reaction
Plate, 72mm Series

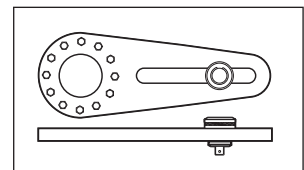

Typical Reaction with sliding 'slave
square', PT/HT1 to PT/HT5

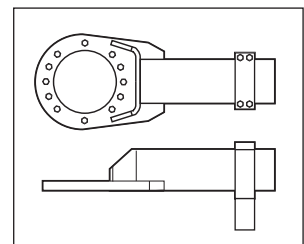

Typical Reaction with adjustable
reaction foot, PT/HT7 and PT/HT9

Torque Reaction Avoiding Torque Reaction Problems

It has already been mentioned that the reaction force is equal to the force being applied. However, the magnitude of the reaction force is dependent upon the perpendicular distance between the point of reaction and the centre line of the multiplier, i.e. the greater the distance the lower the force.

For this reason the point of reaction should be kept as far away from the centre line of the gearbox as is practical.

Customers using or modifying reaction plates for Standard Series multipliers up to a capacity of 3400 N.m should note that if the reaction is taken on the radiused part, the reaction force is perpendicular to the tangent of the curve. Consequently, the further around the radius the reaction is taken, the smaller the perpendicular distance and therefore the greater the force.

Although a longer reaction plate may mean lower forces, the bending moment close to the multiplier will increase.

Customers extending the length of Norbar's standard reaction plates should be aware that an increase in overall length will result in a larger induced bending stress and should not assume that because the reaction plate is strong enough at one length it will remain so when extended.

Excessive side loading, resulting from poor reaction, increases frictional forces inside the multiplier. This can lead to lower multiplication ratios (outside $\pm 4\%$).



Signs of poor reaction are evident on this damaged foot. Reaction was taken at the wrong point on the foot and burring indicates that the foot was slipping off the reaction point.

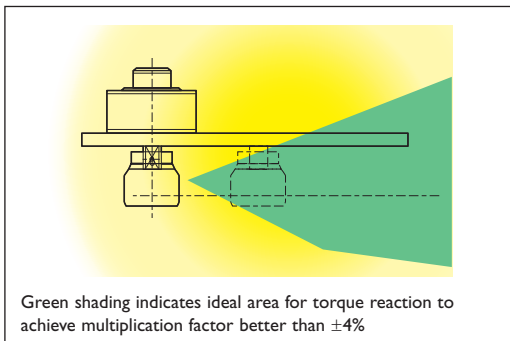

Points to remember

- Take the reaction as far away from the multiplier as practical.
- Ensure that the reaction point remains square to the multiplier wherever possible as this will minimise any additional stress in the output square, which could result in premature failure. If the multiplier tilts under load, the reaction may not be square.
- For applications that do not allow the reaction to be taken securely it is advisable to use a double ended or balanced reaction plate.

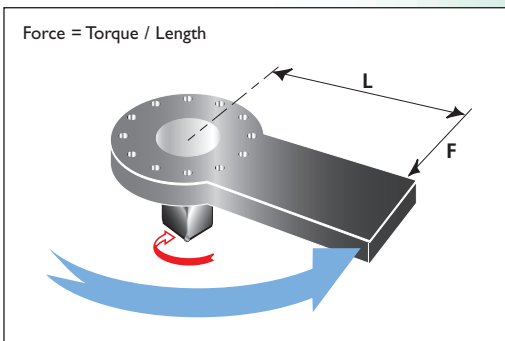
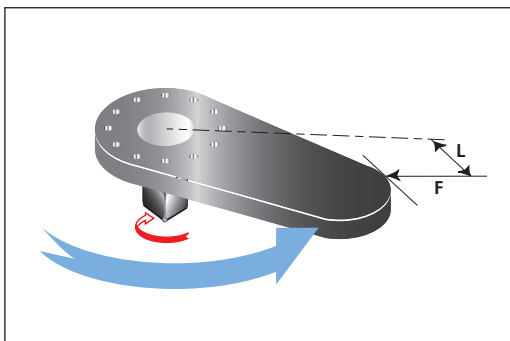

Reaction Force

When using Multipliers and Pneutorques the reaction point must be capable of withstanding reaction force. Therefore, great care must be exercised where reaction is taken when applying high torques to studs and bolts.

By using the following formula you can calculate the force at the point of reaction. The greater the distance the lower the force.

$$\text{Formula to calculate Area of Stud} = \frac{\pi \times D^2}{4}$$

$$\text{Formula to calculate Shear Force: Shear Force} = \frac{\text{Reaction Force}}{\text{Area of Stud}}$$