

NORBAR TORQUE TOOLS HANDTORQUE™ MULTIPLIER AND TORQUE WRENCH KITS



For convenience, it is now possible to purchase a torque multiplier from the “Compact Series” packaged with the appropriate torque wrench. This allows the operator to arrive at the bolting application with everything needed in one robust carry case. Space has been allowed in the carry case for accessories such as sockets.

The torque wrench and torque multiplier are each supplied with their own calibration certificate allowing accurate calculation of input torque to the multiplier for critical applications.

HANDTORQUE™ KITS

Handtorque™ Kit	Handtorque™ Supplied			Torque Wrench Supplied	Kit Length	Kit Width	Kit Depth	Kit Weight
	Model	Ratio	Output Square					
18184 AWUR	HT-52	22:1	3/4"	TTi45 (lbf-ft only)	360 mm	228 mm	135 mm	5.4 kg
18185 AWUR	HT-52	22:1	3/4"	TTi60 (N-m only)	360 mm	228 mm	135 mm	5.4 kg
18186 AWUR	HT-52	22:1	3/4"	TTi60 (Dual Scale)	360 mm	228 mm	135 mm	5.4 kg
18187 AWUR	HT-52	22:1	1"	TTi45 (lbf-ft only)	360 mm	228 mm	135 mm	5.5 kg
18188 AWUR	HT-52	22:1	1"	TTi60 (N-m only)	360 mm	228 mm	135 mm	5.5 kg
18189 AWUR	HT-52	22:1	1"	TTi60 (Dual Scale)	360 mm	228 mm	135 mm	7.7 kg
18190 AWUR	HT-72	27:1	1"	TTi75 (lbf-ft only)	459 mm	319 mm	160 mm	7.7 kg
18191 AWUR	HT-72	27:1	1"	TTi100 (N-m only)	459 mm	319 mm	160 mm	7.7 kg
18192 AWUR	HT-72	27:1	1"	TTi100 (Dual Scale)	459 mm	319 mm	160 mm	7.7 kg
18193 AWUR	HT-92	25:1	1"	TTi150 (lbf-ft only)	459 mm	319 mm	160 mm	12.3 kg
18194 AWUR	HT-92	25:1	1"	TTi200 (N-m only)	459 mm	319 mm	160 mm	12.3 kg
18195 AWUR	HT-92	25:1	1"	TTi200 (Dual Scale)	459 mm	319 mm	160 mm	12.3 kg

For more details on all Norbar products please contact:

NORBAR TORQUE TOOLS LTD
 Beaumont Road, Banbury,
 Oxfordshire OX16 1XJ
 UNITED KINGDOM
 Tel + 44 (0)1295 753600

www.norbar.com

NORBAR TORQUE TOOLS

HANDTORQUE™ MULTIPLIER AND TORQUE WRENCH KITS

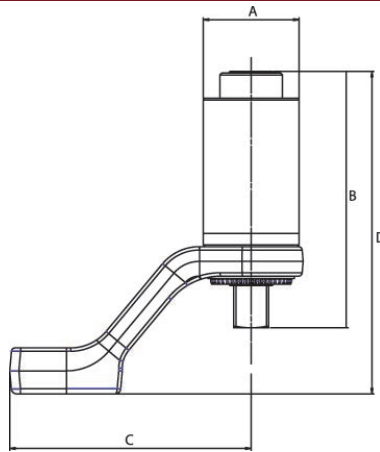

HANDTORQUE™ MULTIPLIER

Model	Ratio	Output Square	Maximum Torque Output		Dimensions				Tool Weight	Reaction Weight	Kit
			N-m	lbf-ft	A	B	C	D			
HT-52 AWUR	22:1	3/4"	1000	740	52 mm	157 mm	131 mm	189 mm	1.4 kg	0.85 kg	18184
											18185
											18186
HT-52 AWUR	22:1	1"	1000	740	52 mm	162 mm	131 mm	189 mm	1.7 kg	0.85 kg	18187
											18188
											18189
HT-72 AWUR	27:1	1"	2000	1450	72 mm	182 mm	164 mm	226 mm	3 kg	0.66 kg	18190
											18191
											18192
HT-92 AWUR	25:1	1"	4000	2950	92 mm	220 mm	205 mm	277 mm	5.4 kg	1.35 kg	18193
											18194
											18195

TORQUE WRENCH

Model	Range		Ratchet Diameter	Length	Weight	Kit
	N-m	lbf-ft				
TTi45	-	10 - 45	38 mm	348 mm	0.9 kg	18184
TTi60	12 - 60	-	38 mm	348 mm	0.9 kg	18185
TTi60	12 - 60	10 - 45	38 mm	348 mm	0.9 kg	18186
TTi45	-	10 - 45	38 mm	348 mm	0.9 kg	18187
TTi60	12 - 60	-	38 mm	348 mm	0.9 kg	18188
TTi60	12 - 60	10 - 45	38 mm	348 mm	0.9 kg	18189
TTi75	-	15 - 75	46 mm	405 mm	1 kg	18190
TTi100	20 - 100	-	46 mm	405 mm	1 kg	18191
TTi100	20 - 100	15 - 75	46 mm	405 mm	1 kg	18192
TTi150	-	30 - 150	46 mm	505 mm	1.2 kg	18193
TTi200	40 - 200	-	46 mm	505 mm	1.2 kg	18194
TTi200	40 - 200	30 - 150	46 mm	505 mm	1.2 kg	18195

For more details on all Norbar products please contact:

NORBAR TORQUE TOOLS LTD
 Beaumont Road, Banbury,
 Oxfordshire OX16 1XJ
 UNITED KINGDOM
 Tel + 44 (0)1295 753600

www.norbar.com